

Model TR32 Digital Temperature Transmitter

ATEX APPROVED

- HART® Protocol
- ATEX Approved
- Universally programmable for
 - RTDs
 - Thermocouples
 - Resistance - sensor
 - mV - sensor
- Output linear to temperature with input signal from RTDs and Thermocouples
- Custom specific linearisation with max. 32 points for sensors with Ω or mV output
- Analog output 4 ... 20 mA, invertible, 2 - wire design
- Signalling individually configurable for possible errors of the sensor system
- Ex class protection, intrinsically safe
 - EEx ia IIB / IIC T4 / T5 / T6
 - EExnA
 - EExd (when fitted in H70 connection head)
- EMC Conformity per
 - EN 61326:1997/A1:1998/A2:2001
 - NAMUR NE 21
- Isolation voltage 1500 VAC between sensor and current loop
- 100 % Rh protection, moisture condensation permissible
- Increased ambient temperature
- Configurable via
 - HART® Communicator
 - PC Windows®-programme
- Terminal connections with captive screws
- CE Conformity



Model TR32 Digital Temperature Transmitter

General Description

The TR32 digital temperature transmitter is designed for universal use in the process industry.

Comprehensive individual configuration properties, for example, type of sensor, measuring range and error signalling, high accuracy, galvanic isolation and excellent EMI protection characterize these transmitters. The compact head mounting case fits in almost any DIN connecting head.

During configuration, by means of a HART communicator model 275 or an FSK modem (eg VIATOR) via the RS 232-C on a standard DOS PC, any one of 15 types of sensor can be selected. Measured temperatures are from -270°C up to 1820°C.

The transmitters are delivered with any customized configuration within the given limits.

The following sensors can be connected:

- RTDs per EN 60 751 resp. DIN 43 760 in 2 - , 3 - and 4 - lead connection, the connection-system used is configurable and ensures an optimal lead wire compensation
- Thermocouples per IEC 584 , DIN 43 710 and ASTM E988 Cold junction compensation (CJC) is built-in, the use of an external CJC is selectable via configuration.
- Resistance-sensors up to 5 k Ω in 2 - , 3 - and 4 - lead connection, configurable compensation of the connection cable
- mV-sensors up to 1200 mV

TR32 Dimensions

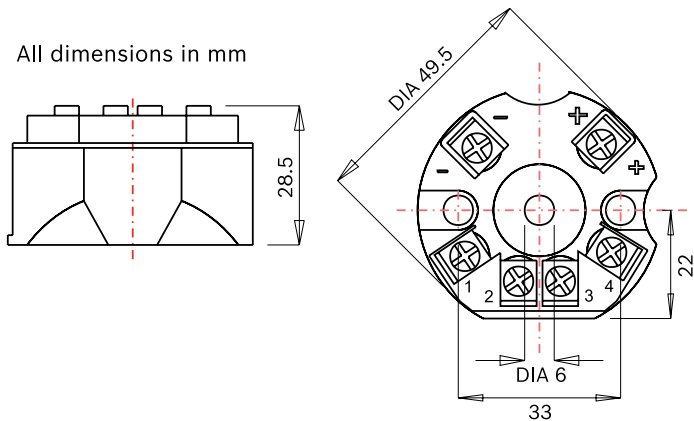

TR32 Wiring Scheme

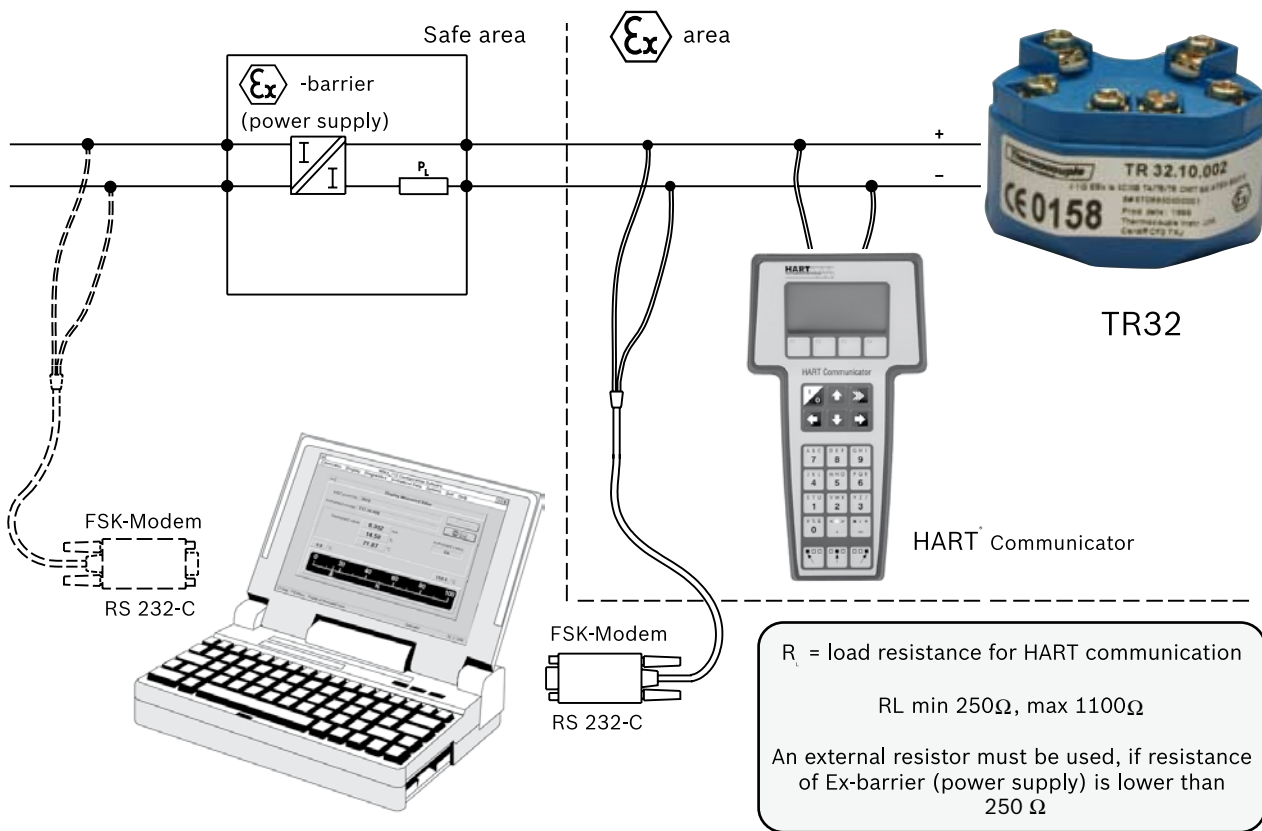

TR12 Designation of Terminal Connectors

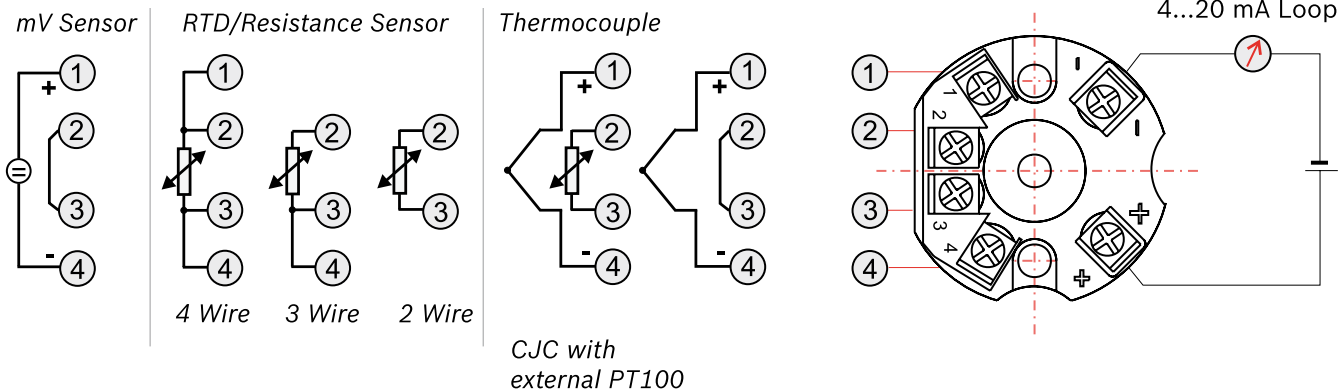

TR32 - Input Types

Sensor Type			Max. Measuring Range	Min Measuring Span ⁽¹⁾
RTD	PT 100	EN60751	-200 to +850°C ⁽¹⁾	10 K or 3.8 Ω whichever is greater
	JPt 100	JIS Z 8710	-200 to +500°C	
	Ni 100	DIN 43760 : 1987-09	-60 to +250°C	
Thermocouple	Type T Cu-CuNi	IEC 584	-270 to +400°C	50 K or 2 mV whichever is greater
	Type E NiCr-CuNi	IEC 584	-270 to +1000°C	
	Type J Fe-CuNi	IEC 584	-210 to +1200°C	
	Type L Fe-CuNi	DIN 43710 : 1985-12	-200 to +900°C	
	Type K NiCr-Ni	IEC 584	-270 to +1372°C	
	Type N NiCrSi-NiSi	IEC 584	-270 to +1300°C	
	Type U Cu-CuNi	DIN 43710 : 1985-12	-200 to +600°C	
	Type R PtRh-Pt	IEC 584	-50 to +1768°C	
	Type S PtRh-Pt	IEC 584	-50 to +1768°C	
	Type B PtRh-PtRh	IEC 584	0 to +1820°C	
Resistance Sensor			0 to 700 Ω / 5000 Ω	4 Ω / 32 Ω
mV Sensor			-400 to +1200 mV	2 mV up to 32 mV

TR32 - Input Specification

RTD/Resistance Sensor	Measuring deviation per DIN IEC 770, 23°C ±5K	RTD	± 0.08 K
		Resistance Sensor	± 0.03 Ω or ± 0.006% FS in Ω whichever is greater
	Sensor current		Approx. 0.2 mA
	Temperature coefficient T _c	RTD	± (0.02% FS + 0.09) K / 10 K _{Tamb}
		Resistance Sensor	± (0.02% FS + 0.01) K / 10 Ω _{Tamb}
	Lead wire connection		Configurable: 2, 3 or 4 lead
	Connection Leads	Max permissible resistance	30 Ω each lead, 3-lead symmetric
		Effect	±0.02 Ω / 10 Ω
Signalling of sensor error		Configurable	
Thermocouple	Measuring deviation ⁽²⁾ per DIN IEC 770, 23°C ± 5K		± 0.3 K or ± 5 μV whichever is greater
	Cold junction compensation at 23°C ± 5K		± 0.8 K
	Temperature coefficient T _c of cold junction compensation		± 0.1 K / 10 K _{Tamb}
	Temperature coefficient T _c	Type T, E, J, L, K, N, U	± (0.03% FS + 0.07) K / 10 K _{Tamb}
		R, S, B	± (0.03% FS + 0.40) K / 10 K _{Tamb}
	Connection Leads	Max permissible resistance	250 Ω
Effect		± 0.1 μV / 10 Ω	
Signalling of sensor error		Configurable	
mV Sensor	Measuring deviation per DIN IEC 770, 23°C ± 5K		± 5 μV or ¹ ± 0.006% FS in mV whichever is greater
	Temperature coefficient T _c		± (0.03% FS + 0.002) mV / 10 K _{Tamb}
	Connection Leads	Max permissible resistance	250 Ω
		Effect	± 0.1 μV / 10 Ω

TR32 - Output Specification

RTD	Linear to temperature per EN60751 / DIN 43 760 : 1987-09	
Thermocouple	Linear to temperature per DIN IEC 584 / DIN 43 710 : 1985-12	
Simulation Mode	Independent from signal, simulation value configurable from 3.5mA up to 22.5mA	
Output Limits	Application specification	Lower limit: from 3.6 mA to 4.0 mA Upper limit: from 20.0 mA to 21.5 mA
	NAMUR NE 43	Lower limit: 3.8 mA upper limit: 20.5 mA
	Not active	Lower limit: 3.6 mA upper limit: 21.5 mA
Load R _A	R _A ≤ (U _B - 12V) / 0.022 A with R _A in Ω and U _B in V	
Load effect	No measurable effect	
Measuring deviation per DIN IEC 770, 23°, ± 5 K	< ± 0.04% or measuring span	
Temperature coefficient	± 0.1 % of measuring span / 10 K _{Tamb}	
Damping	Configurable: minimum 0.5 s , 1 s up to 60 s	
Measured value update	Approx. 3/s	
Power supply effect	No measurable effect	

TR32 - Power Supply U_B

Model TR32 without Ex-protection	DC 12 ... 42 V
Model TR32 with Ex-protection	DC 12 ... 30 V
Input power supply protection	Reverse polarity

Ex Protection EC Type Test

Model TR32.10.002	II 1G EEx ia IIB / IIC T4/T5/T6	Certificate No.: DMT 00 ATEX E015X
Model TR32.10.009	EExnA IIC T4/T5/T6	Certificate No.: DMT 00 ATEX E080X
Permissible ambient temperatures	-50 °C ... +85 °C with T4 -50 °C ... +75 °C with T5 -50 °C ... +60 °C with T6	
Maximum values for connection of the current loop circuit (connections +/-)	U _i = 30V I _i = 130mA P _i = 800mW L _i = 100µH C _i = 7.8nF	
Maximum values for connection of the sensor circuit (connections 1- 4)	U _o = 11.5V I _o = 5.2mA P _o = 15mW Group IIB: C _o = 11 µF L _o = 1mH Group IIC: C _o = 1.6 µF L _o = 1mH	

TR32 - Total Measuring Deviation

Sum of input and output per DIN IEC 770, 23°C ±5K

TR32 - Signalling - analogue output with sensor error or internal malfunction

NAMUR NE 43	Up-scale	> 21.0 mA
	Down-scale	< 3.6 mA
Configurable	Up-scale	12 mA up to 22.5 mA
	Down-scale	3.5 mA up to 12 mA

TR32 - Electromagnetic Compatibility

CE – Conformity per EMC Directive 89/336/EEC. EN61326:1997/A1: 1998/A2:2001

TR32 - Case

Material	Plastic	
Degree of protection	Case	IP66 EN 60529 / IE 529
	Terminal connections	IP00 EN 60529 / IE 529
Cross section of terminal connections	max. 1.5 mm ² , screws captive	
Weight	Approx. 70 g	
Dimensions	see drawings (page 15)	

TR32 - Special Features

Isolation voltage (input versus analogue output)	1500 VAC, 60s	
Ambient and storage temperature	Standard	-40 ... +85 °C
	Optional	-50 °C... +105 °C ⁽¹⁾
Climate application class	GPA DIN 40040	
Maximum permissible humidity	100 % relative humidity (unlimited with isolated sensor connection wires), moisture condensation permissible DIN IEC 68 2-30 Var. 2	
Vibration	10 ... 2000 Hz 5g DIN IEC 68 2-6	
Shock	DIN IEC 68 2-27 g _N = 30	
Salt fog	DIN IEC 68 2-11	
Configuration and calibration data	Permanently stored in EEPROM	
Testing current to monitor sensor	nom. 1 µA during testing cycle, otherwise 0 µA	
Self-monitoring	Automatic execution of initial test after connection to power supply, thereafter monitoring due to internal malfunction	
Warm-up time	Approx. 5 Min.	
Communication	HART® protocol	
Guarantee	5 years when used within standard ambient range. Rototherm standard terms of warranty apply.	

- 1) Increased up to 1000°C
2) Valid only for configured measuring range beginning ≥ -150°C

- FS - full scale value of configured measuring range
R_A - load
T_c - temperature coefficient
T_{amb} - ambient temperature



British Rotherm Company Limited

Kenfig Industrial Estate, Margam, Port Talbot SA13 2PW United Kingdom

Telephone : +44 (0) 1656 740 551 **Facsimile** : +44 (0) 1656 745 915

E-mail : sales@rototherm.co.uk

Web Site : www.rototherm.co.uk

sales@thermocouple.co.uk

www.thermocouple.co.uk



