

Model TR24 Digital Temperature Transmitter

- Configurable with Windows® PC without sensor simulation
- Analogue signal processing, ideal for multiplex systems
- Quick response <1 ms to 90%
- Sensor burnout signalling according to NAMUR NE 43
- Electromagnetic compatibility according to NAMUR NE 21
- Measuring span from 20 K
- Compact design

General Description

Temperature transmitter for Pt100 in 2 or 3 wire connection with 4...20mA analogue output (loop powered 2 wire technique)

The TR24 temperature transmitter combines the known quick response of an analogue transmitter with the flexibility of configuration by means of a Windows PC.

The quick stabilisation of the output current after excitation voltage has been applied enables the use of this transmitter in multiplex systems.

Setting of the measuring range, type of sensor and sensor burnout behavior takes only a matter of seconds thanks to the easy to use Windows configuration software. Time consuming adjustments and sensor simulation are not required for this transmitter.

The TR24 can be remotely configured from the control room via the current loop. Possible measuring errors which might for example, result from poor thermometer position, can be compensated by means of the function 'sensor correction'.

Write protection and an increased ambient temperatures range complete the spectrum of features offered by the temperature transmitter.

TR24 Dimensions

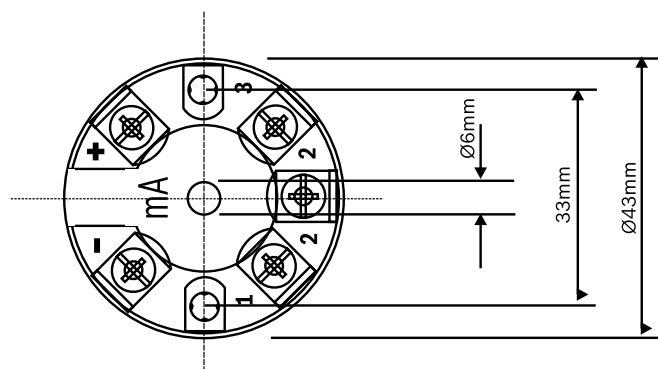
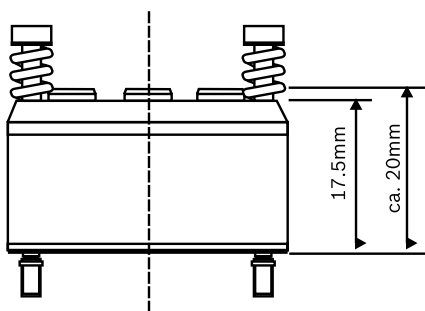

All dimensions are in mm. Drawings are for illustration purposes only



Model TR24 Temperature Transmitter

Due to its flexibility and reliability the TR24 temperature transmitter is suited for a wide range of applications in the machine industry and plant construction.

As a result of its extremely compact design this TR24 temperature transmitter can be fitted into any DIN connection head of form B.

The transmitters are delivered with a basic configuration. Alternatively, upon request, transmitters can be delivered with a customized configuration within the given limits.

TR24 Connection of Programming Unit

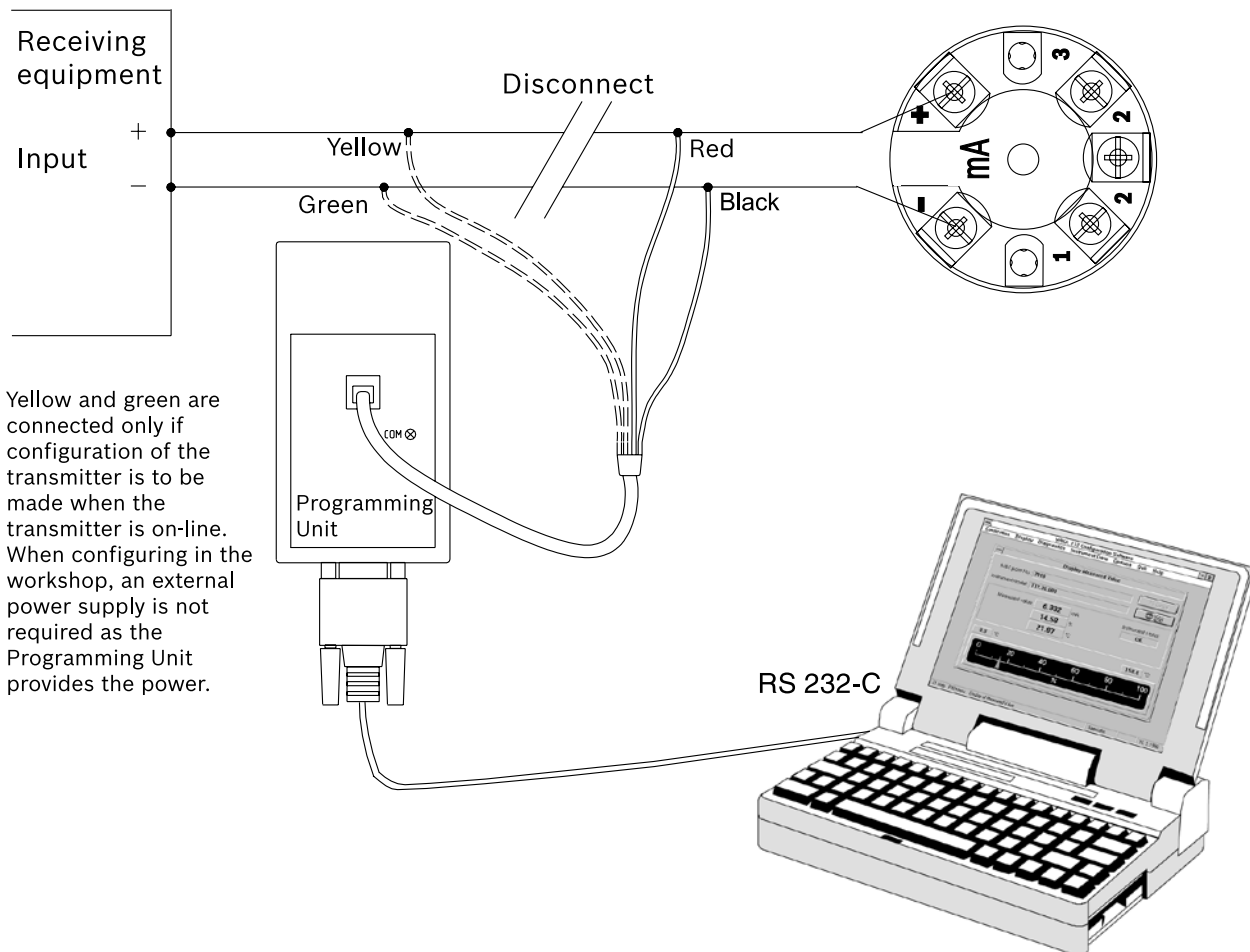

TR24 Designation of Terminal Connectors

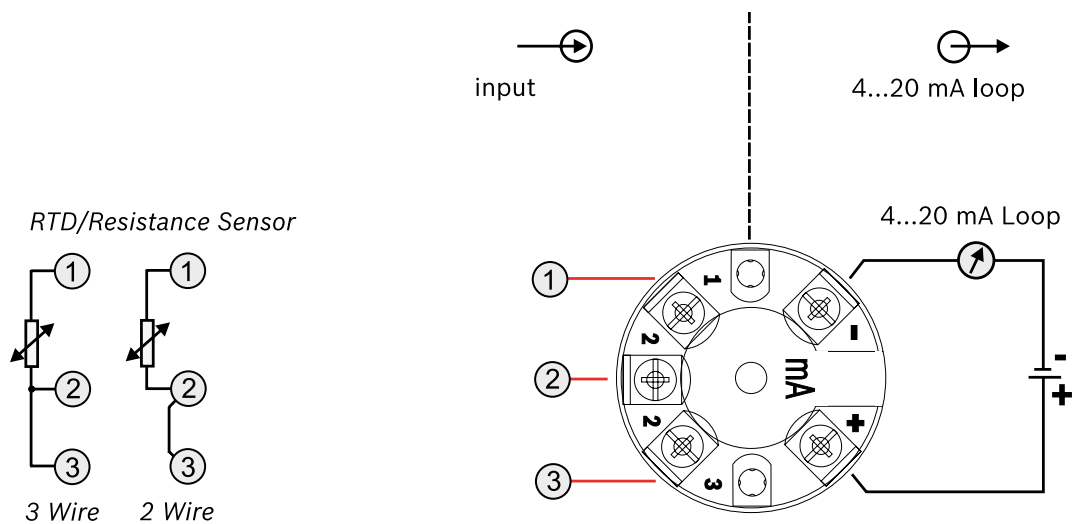

TR24 - Specifications

Input		Measuring range configurable with Windows® PC
Model TR24		Pt100 DIN EN 60 751 2 wire, 3 wire
Measuring range maximum		TR24 -150°C...+850°C
Measuring span		TR24 minimum 20 K
Initial value of measuring range, configurable		TR24 -150°C...+150°C
Basic configuration		3 wire 0...150°C
Sensor current		approx. 0.5 mA
Connection leads	Effect	±0.2 K / 10 Ω each wire ⁽¹⁾
	Permissible load resistance	30 Ω each wire, 3 wire symmetric
Analogue Output		4...20 mA, 2 wire design
Measuring deviation per DIN EN 60770, 23°C ±5K		±0.2% ⁽²⁾
Linearization		Linear to temperature per DIN EN 60751
Linearity error		±0.1% ⁽³⁾
Temperature coefficient T_K	zero	±0.1% / 10 K _{Ta} or ⁽⁴⁾ ±0.15K/10 K _{Ta}
	span	±0.15% / 10 K _{Ta}
Rising time t_{90}		< 1ms
Switch-on delay, electric		< 10 ms
Signalling	sensor burnout	Configurable NAMUR downscale < 3.6mA (typical 3 mA) ⁽⁵⁾ Configurable NAMUR upscale > 21.0 mA (typical 23 mA)
	sensor short circuit	Not configurable, in general NAMUR downscale < 3.6mA (typical 3 mA) ⁽⁵⁾
Load R_A		$R_A < (U_B - 10V) / 0.022A$ with R_A in Ω and U_B in V
Load effect		± 0.05% / 100 Ω
Power supply effect		±0.025% / V
Power Supply		By the 4...20mA-loop
Model TR24 (without Ex-protection)		DC 10....36 V
Input power supply protection		Reverse polarity
Max. permissible ripple		10 with 24V / maximum load 300 Ω
Electromagnetic Compatibility (EMC)		per EMC Directive 89/336/EWG DIN EN 61 326:2002 and additional NAMUR NE 21 (August 98)
Ambient Conditions		
Ambient and storage temperatures		Standard range -40 to +85°C Extended range (option): -50 to +85°C or -40 to +105°C ⁽⁶⁾
Climate class		Cx(-40 to +85°C, 5% up to 95% relative humidity) DIN EN 60 654-1
Maximum permissible humidity		100% relative humidity, moisture condensation permissible DIN EN 60068-2-30 Var. 2
Vibration		10 to 2000 Hz 10g DIN EN 60 068-2-6
Shock		DIN EN 60 068-2-27
Salt fog		DIN EN 60 068-2-11

Load Diagram

The permissible load is dependent upon the loop power supply voltage

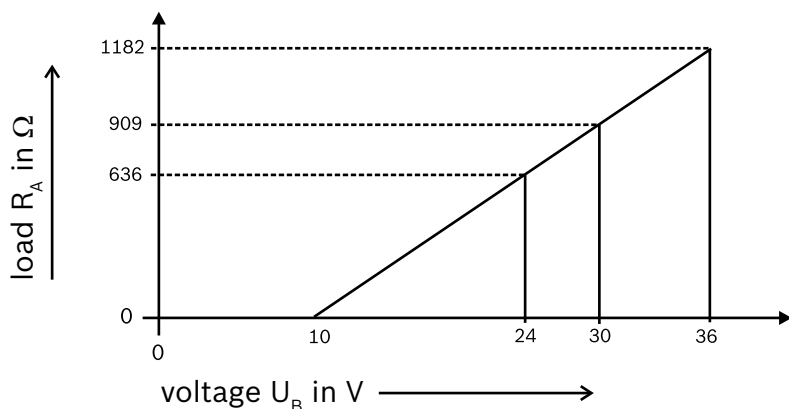

Specifications in % refers to the measuring span.

R_A Load
 T_a ambient temperature
 T_C temperature coefficient
 U_B loop power supply voltage, see power supply

Wire Number:

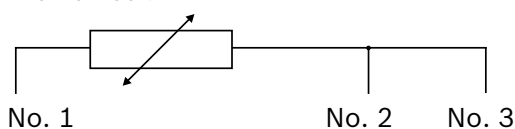

Special features		
Temperature units		Configurable: °C, °F, K
Resistance Sensor		Linear resistance sensors are connectable
Sensor connection		Configurable: 3 wire or 2 wire configurable compensation of lead resistance with 2 wire connection
Info data		TAG-N0., descriptor and Message via configuration storeable in transmitter
Configuration and calibration data		Permanently stored in EEPROM
Case		Head Mounting design, including spring loaded mounting screws
Material		Plastic, PBT, glass fibre reinforced
Ingress protection	case	IP 50 IEX 529 / EN 60 529
	terminal connections	IP 00 IEX 529 / EN 60 529
Cross section of terminal connectors		0.14 to 1.5 mm ²
Weight		Approx. 0.04 kg
Dimensions		See drawings on page 19

- (1) For 3 wire sensor connection, with 2 wire connection a total lead resistance up to 20 Ω is compensatable, otherwise the lead resistance causes additional error
- (2) For measuring span lower than 50K additional: 0.1 K
For measuring span higher than 550K additional: 0.1%
- (3) ±0.2% with measuring ranges with initial value lower than 0°C or measuring span higher than 800K
- (4) Whichever is greater between the standard range of ambient temperature $-40^{\circ}\text{C} \leq T_a \leq +85^{\circ}\text{C}$, with option "extended range of ambient temperature" the double value is valid outside the standard range
- (5) Temperature value, in case of short between wire no. 2 and no. 3 (operation of sensor in 2 wire connection)
- (6) -40 to +105°C only without EX-protection



British Rototherm Company Limited

Kenfig Industrial Estate, Margam, Port Talbot SA13 2PW United Kingdom

Telephone : +44 (0) 1656 740 551 Facsimile : +44 (0) 1656 745 915

E-mail : sales@rototherm.co.uk

Web Site : www.rototherm.co.uk

sales@thermocouple.co.uk

www.thermocouple.co.uk

