

# Flow Product Catalogue



Orifice Plates | Restriction Orifice Plates | Orifice Flanges | Carrier Assemblies | Venturi Tubes  
Pitot Tubes | Meter Runs | Differential Pressure Gauges | Flow Recorders

# Introduction

British Rototherm / Thermocouple Instruments is an established manufacturer of custom designed process measurement equipment for a wide range of industries including Petrochemical, Oil and Gas, Chemical, Contract Engineering, Pharmaceutical, Food and Brewing, Power, Steel and Water.

We pride ourselves on our strength and versatility, expressed by our ability to design and manufacture to your exact requirements. This is really where our in-house expertise excels and can tailor the exact solutions to your needs.

Our strong technical advice and software programmes, designed in-house, help to make your measurements accurate, reliable and easier to attain.

Our quality process is crucial to our service and our ISO 9001 and ATEX approved assemblies ensure you get quality service not only from the product, but also from the moment you call us.

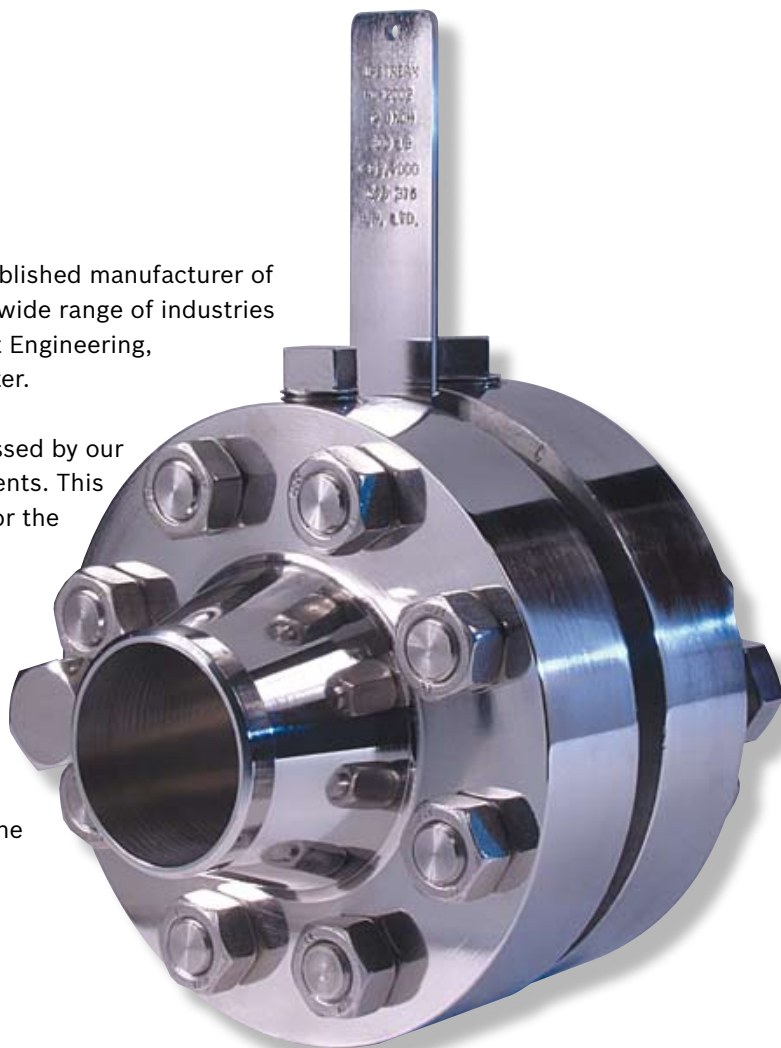

## Our Mission

It is our philosophy that the customer is the absolute priority. We have a duty to maintain this principle, and we believe it will give us the edge over our competitors.

We have a highly trained team of sales engineers who listen to, and understand your needs, to achieve the very best solutions with the minimum of fuss.

Our drawing office is extremely experienced and can provide detailed drawings of your requirements prior to manufacture. Customer satisfaction and approval, particularly at these early stages, means everything.

From planning, through manufacture, assembly and testing our quality management systems ensures your expectations are exceeded.

## Total Package Solution

Total Package Solution is aimed at giving all our customers temperature, pressure and flow measurement solutions, custom designed to enable a “one-stop-shop” convenience combined with cost effectiveness.

Also as part of our Total Package Solution, we can provide a range of high class technical expertise and software to help with any questions, concerns or calculations you may have.

# Contents

<b>Flow Products - an overview</b>	3
<b>Tab Handled Orifice Plates</b>	4
Recommended Orifice Plate Thicknesses	4
Orifice Bore Sizing	4
Orifice Carrier Assemblies	4
Orifice Plate Types	5
Standard Orifice Plate Dimensions for ANSI Flanges	5
<b>Restriction Orifice Plates</b>	6
Recommended Plate Thicknesses	6
<b>RTJ Type Orifice Plates</b>	7
Standard Orifice Plate and Ring Dimensions	8
<b>Orifice Carrier Assemblies</b>	9
Pressure Tapping Orientation	9
Double Ring Orifice Carriers	10
Annular Chamber Orifice Carriers	11
Single Ring Orifice Carriers	12
<b>ANSI B16.36 Orifice Flanges</b>	13
Weldneck Orifice Flange Assemblies	14
Slip-On Orifice Flange Assemblies	16
<b>DPCalc - Flow Element Sizing Software</b>	17
Fluid Property Data	18
<b>Venturi Tubes and Venturi Nozzles</b>	19
<b>Averaging Pitot Tubes</b>	21
<b>Meter Runs</b>	24
<b>Differential Pressure Gauges</b>	25
Differential Pressure Gauges - light to medium duty	25
Differential Pressure Gauges - medium to heavy duty	26
<b>Clearscan Flow Recorder</b>	27
<b>Orifice Plates, Flow Nozzles &amp; Venturi Tubes - Installation Instructions</b>	29
Pressure Connections	29
Position of Tappings	29
Piping	29
Direction of Flow	30
Gaskets	30
Installation of DP Transmitter	31
Maintenance	32
<b>Orifice Bore Technical Data Requirements</b>	32
<b>Other Products Available</b>	33

# Flow Products - an overview

Accurate and reliable flow measurement equipment is essential for all types of industry processes all over the world. Whatever your process requirement for flow measurement, be it water, oil and gas, air, steam, waste water or other fluid, we have the answer, combined with the added flexibility of designing and manufacturing a system to suit your requirements.

Our vast knowledge and experience of providing solutions for organisations worldwide has proven our understated capability to provide the complete range of flow measurement equipment.

Our custom-designed measurement solutions are typically of the differential pressure (DP) type, including orifice plates, Venturi tubes, Pitot tubes and flow nozzles.

## Orifice Plates

The most common and widely used differential producers, suitable for a wide range of flow measurement applications in line sizes of 50 mm and above. Choose 'concentric square edged' for general application, 'conical entrance' or 'quarter circle' for low Reynolds number flows, and 'segmental' or 'eccentric' for flows containing light solids and slurries.

## Flow Nozzles

For measurements where high temperatures and velocities are present, the flow nozzle may provide a better solution than an orifice plate. Its construction makes it substantially more rigid in these adverse conditions and flow coefficient data at high Reynolds numbers is better documented than for orifice plates. The inlet is contoured, and may be either radius entrance (ISA1932) or elliptical entrance (ASME long radius). The flow nozzle has about a 65% greater flow capacity than an orifice with the same diameter.

## Venturi Tubes

There are two common types of Venturi tube - the Venturi nozzle, and the classical Venturi. Both feature a convergent inlet section and a divergent outlet section. The major advantage of the Venturi over orifice plates and flow nozzles is in the area of pressure recovery. Typically, unrecovered pressure is in the region of 10 - 30% of measured DP as opposed to 40 - 90% for an orifice plate (depending on beta ratio). Although the cost of a Venturi can be comparatively high, where pumping costs are important the initial outlay can be justified. Another advantage of the classical Venturi over the other differential pressure producers is that the requirements for upstream and downstream straight pipe lengths are somewhat less onerous.

## Pitot Tubes

These practical and effective DP primary elements can, in some applications, match Venturis in terms of performance at a substantial cost advantage, especially for large diameter pipelines. A number of upstream facing ports effectively average the velocity profile and allow for measurement of impact, or stagnation pressure, and a pressure port (or ports) located behind the tube measures the static pressure, the difference being used to infer the flow rate. The differential pressures produced from such devices are considerably lower than from the other DP elements, which can limit their usefulness in certain applications. However, they present little resistance to the flow and as such exhibit excellent unrecovered pressure loss characteristics (it may be considered as negligible in many circumstances). Installation of averaging Pitots is simple and inexpensive, and since there are no sharp edges to wear, averaging Pitot tubes offer good long term accuracy.

## Differential Pressure Gauges

A range of high quality, cost effective and reliable differential pressure gauges designed to measure the difference in pressure between two points in a system and show it on a single dial gauge.

With their simple and compact design this range offers outstanding value for money.

## Flow Recorders

Utilising a high quality differential pressure unit, the Clearscan range of circular chart recorders includes options for measuring temperature and pressure as well as flow.

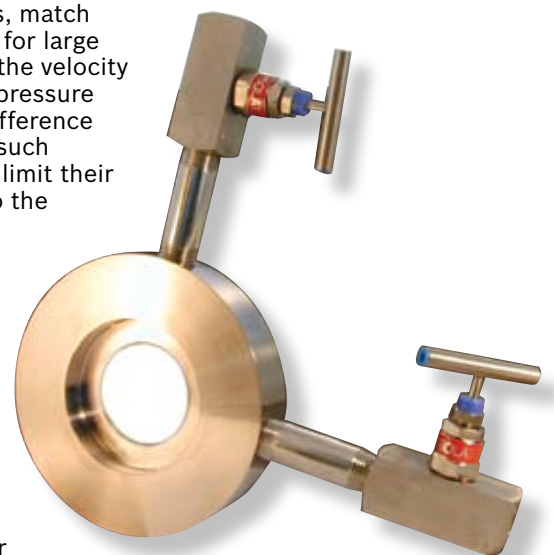

# Tab Handled Orifice Plates

- Design to BS EN ISO 5167
- Range of Orifice Types
  - Concentric Square Edge
  - Conical Entrance
  - Quarter Circle
  - Segmental
  - Eccentric
- Wide range of materials
- Proven technology
- Suitable for 1" lines and above
- Orifice sizing on request

## General Description

The orifice plate is the most common differential pressure flow primary element. It is based on proven technology, has no moving parts and is suitable for high temperature and pressure applications. Orifice plates are recommended for clean liquids, gases and low velocity steam flows.

## Dimensions

The outside diameter of the orifice plate is equal to the bolt circle diameter of the connecting flanges minus the diameter of the bolt. This ensures that the plate is centred accurately in the line.

Plate thicknesses depend on line size and differential pressure, and should be sufficient to prevent the plate from bending under operating conditions. Recommended plate thicknesses are shown below.

Standard plate dimensions are shown overleaf. Orifice plates can be made in accordance with customer drawings as required.

Pipe Diameter	Standard Plate Thickness (mm) for Differential Pressure $\Delta P$		
	$\Delta P = 250$ mbar	$\Delta P = 251 - 500$ mbar	$\Delta P = 501 - 2500$ mbar
$D \leq 150$ mm	3	3	3
$200 \leq D \leq 250$	3	3	6
$300 \leq D \leq 500$	6	6	10
$600 \leq D \leq 900$			
$\beta \leq 0.5$	10	10	12
$\beta > 0.5$	6	10	12

*Recommended Orifice Plate Thicknesses*

## Materials

Standard material grades include 316 Stainless Steel, 304 Stainless Steel, 310 Stainless Steel, Hastelloy® C276, Hastelloy® B3, Duplex Stainless Steel, Super Duplex Stainless Steel, Monel® 400, Carbon Steel, Titanium, Incoloy® 800, Incoloy® 825, Inconel® 600, Inconel® 625, Tantalum, PTFE and PVDF.

Please contact the sales office for other grades.

*Incoloy, Inconel and Monel are trademarks of INCO Alloys International Inc.*

*Hastelloy is a trademark of Haynes International Inc.*



*Measuring the Orifice Diameter*

## Orifice Bore Sizing

Orifice calculations are performed to the latest revision of BS EN ISO 5167, when requested.

The Thermocouple Instruments sizing program, DPCalc, is also available for purchase. Refer to page 17.

## Orifice Carrier Assemblies

Orifice plates can be supplied complete with one or two piece orifice carriers, or ANSI B16.36 orifice flanges. Orifice meter runs are also available.

### Orifice Plate Types

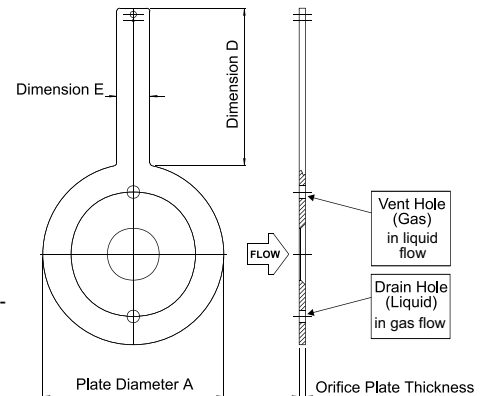
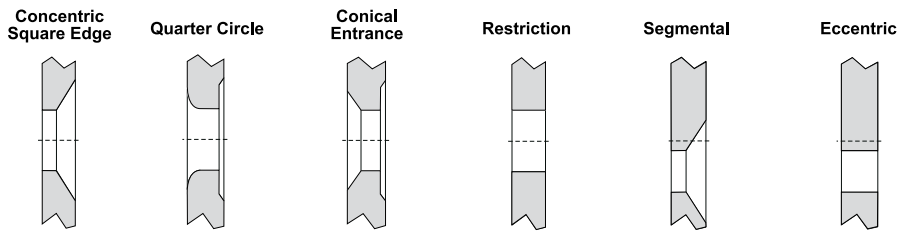

**Square Edge**  
For general applications in clean fluids - the most widely used design. Suitable for pipes up to 1000 mm diameter.

**Quarter Circle**  
Suitable for measurement of low Reynolds number flows in pipelines of diameter less than 750 mm.

**Conical Entrance**  
Suitable for measurement of very low Reynolds number flows - easier to manufacture than quarter circle types.

**Restriction**  
Please refer to page 6.

**Segmental**  
Suitable for measurement of dirty

fluids and 2 phase flow - allows passage of extraneous matter. Suitable for pipes up to 350mm

**Eccentric**  
Suitable for measurement of dirty fluids and 2 phase flow, preferred to segmental pipelines of diameters less than 350 mm.

Nominal Line Size		150 LB			300 LB			400 LB			600 LB			900 LB			1500 LB			2500 LB		
mm	IN	A	D	E	A	D	E	A	D	E	A	D	E	A	D	E	A	D	E	A	D	E
15	1/2	47.6	125	25	54	125	28	54	125	28	54	125	32	63.5	125	28	63.5	125	32	69.9	125	32
20	3/4	57.2	125	32	66.7	125	32	66.7	125	32	66.7	125	32	69.9	125	32	69.9	125	32	76.2	125	32
25	1	66.7	125	32	73	125	32	73	125	32	73	125	32	79.4	125	32	79.4	125	32	85.7	150	32
30	1 1/4	76.2	125	32	82.6	125	32	82.6	125	32	82.6	125	32	88.9	125	32	88.9	125	32	104.8	150	32
40	1 1/2	85.7	125	32	95.3	125	32	95.3	125	32	95.3	125	32	98.4	125	32	98.4	125	32	117.5	150	32
50	2	104.8	125	32	111.1	125	28	111.1	125	28	111.1	125	28	142.9	150	32	142.9	150	32	146	150	32
65	2 1/2	123.8	125	32	130.2	125	32	130.2	125	32	130.2	125	32	165.1	150	32	165.1	150	32	168.3	150	32
80	3	136.5	125	32	149.2	125	32	149.2	125	32	149.2	125	32	168.3	150	32	174.6	150	32	196.9	150	32
100	4	174.6	150	32	181	150	32	177.8	150	32	193.7	150	32	206.4	150	32	209.6	150	32	235	150	32
125	5	196.9	150	32	215.9	150	32	212.7	150	32	241.3	150	32	247.7	150	32	254	150	32	279.4	175	32
150	6	222.3	150	32	250.8	150	32	247.7	150	32	266.7	150	32	288.9	150	32	282.6	150	32	317.5	175	32
200	8	279.4	150	32	308	150	32	304.8	150	32	320.7	150	32	358.8	175	32	352.4	175	32	387.4	175	32
250	10	339.7	150	32	362	150	32	358.8	150	32	400	150	32	435	175	32	435	175	32	476.3	200	32
300	12	409.6	150	32	422.3	150	32	419.1	150	32	457.2	150	32	498.5	175	32	520.7	175	32	549.3	200	32
350	14	450.9	150	32	485.8	150	32	482.6	150	32	492.1	150	32	520.7	175	32	577.9	175	32	-	-	-
400	16	514.4	150	32	539.8	150	32	536.6	150	32	565.2	150	32	574.7	200	32	641.4	200	32	-	-	-
450	18	546.1	175	32	593.7	175	32	587.4	175	32	609.6	175	32	635	200	32	701.7	200	32	-	-	-
500	20	603.3	175	32	650.8	175	32	644.5	175	32	679.5	175	32	695.3	200	32	752.5	200	32	-	-	-

Standard Orifice Plate Dimensions for ANSI Flanges

# Restriction Orifice Plates

- **Manufactured generally to BS EN ISO 5167**
- **Wide range of materials**
- **Proven technology**
- **Suitable for most pipe sizes**
- **Orifice sizing on request**

## General Description

Restriction orifice plates can be used as a simple pressure reducing device, or to limit the flow rate in a pipeline. They are designed to slip between pipe flanges. Versions to suit RTJ type flanges are available (see page 7).

## Dimensions

The outside diameter of the orifice plate is equal to the bolt circle diameter of the connecting flanges minus the diameter of the bolt. This ensures that the plate is centred accurately in the line.

Plate thicknesses depend on line size and differential pressure, and should be sufficient to prevent the plate from bending under operating conditions. Recommended plate thicknesses are shown on the graph below.

Orifice plates can be made in accordance with customer drawings as required.

## Materials

Standard material grades include 316 Stainless Steel, 304 Stainless Steel, 310 Stainless Steel, Hastelloy® C276, Hastelloy® B3, Duplex Stainless Steel, Super Duplex Stainless Steel, Monel® 400, Carbon Steel, Titanium, Incoloy® 800, Incoloy® 825, Inconel® 600, Inconel® 625, Tantalum, PTFE and PVDF.

Please contact the sales office for other grades.

## Recommended Plate Thickness

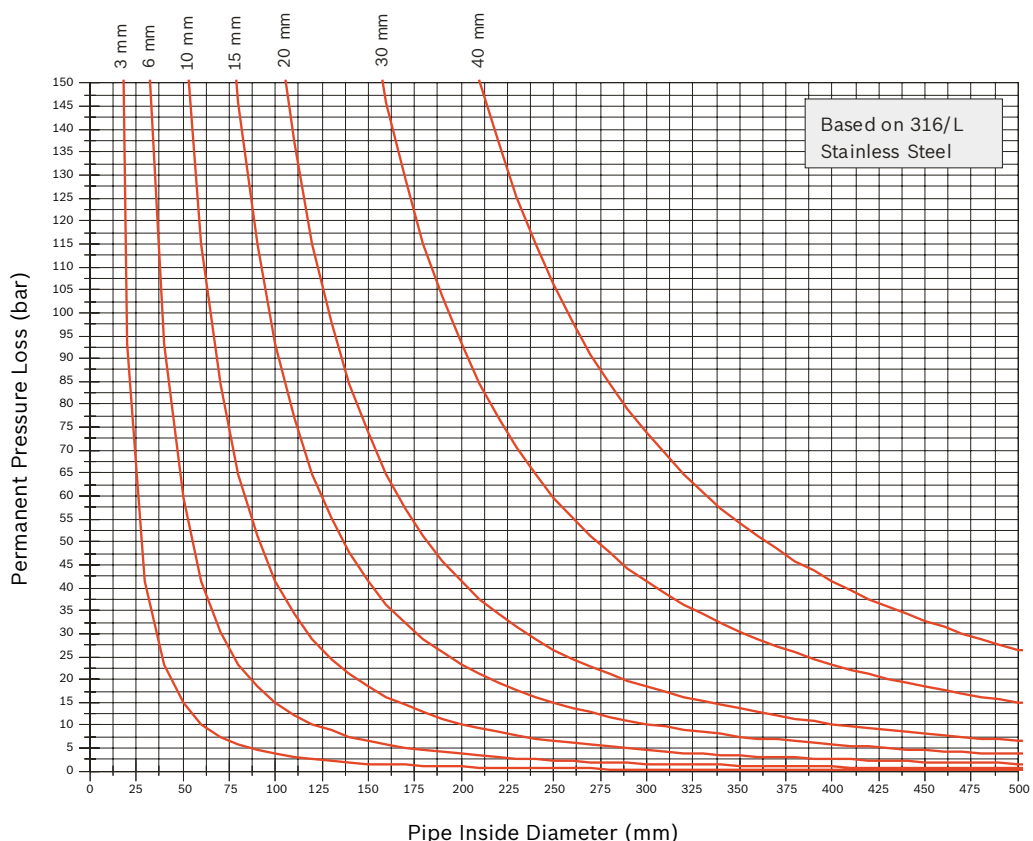

## Orifice Bore Sizing

Orifice calculations are performed generally in accordance with the formulae detailed in RW Miller's Flow Measurement Handbook, when requested.

The Thermocouple Instruments restriction orifice sizing program, ROCalc, is also available for purchase.

## RTJ Type Orifice Plates

- Design Generally to BS EN ISO 5167
- Range of Orifice Types
  - Concentric Square Edge
  - Restriction
- Range of Designs
  - One Piece Construction
  - Screwed On Plate
- Proven technology
- Suitable for 1" lines and above
- Orifice sizing on request

### General Description

The RTJ type orifice plate incorporates an integral gasket, either oval or octagonal ring, for mounting between ring type joint flanges. It is based on proven technology, has no moving parts and is suitable for high temperature and pressure applications. Orifice plates are recommended for clean liquids, gases and low velocity steam flows.

### Dimensions

Plate thicknesses depend on line size and differential pressure, and should be sufficient to prevent the plate from bending under operating conditions. Recommended plate thicknesses for flow measurement plates are shown on page 5.

Standard plate and ring dimensions are shown on page 9. Orifice plates can be made in accordance with customer drawings as required.

### Materials

RTJ type orifice plates may be machined in one piece, or alternatively from two pieces, with an orifice plate screwed



RTJ Type Orifice Plate

onto a carrier ring/gasket. Standard material grades for orifice plates include 316 Stainless Steel, 304 Stainless Steel, 310 Stainless Steel, Hastelloy® C276, Hastelloy® B3, Duplex Stainless Steel, Super Duplex Stainless Steel, Monel® 400, Carbon Steel, Titanium, Incoloy® 800, Incoloy® 825, Inconel® 600 and Inconel® 625.

Common carrier ring/gasket materials include Stainless Steel and soft iron. To ensure correct sealing when installed between flanges, the hardness of the carrier ring/gasket material is limited to a maximum value, typically 120HB for soft iron rings and 160HB for Stainless Steel Rings.

Please contact the sales office for other grades.

### Standard Plate and Ring Dimensions

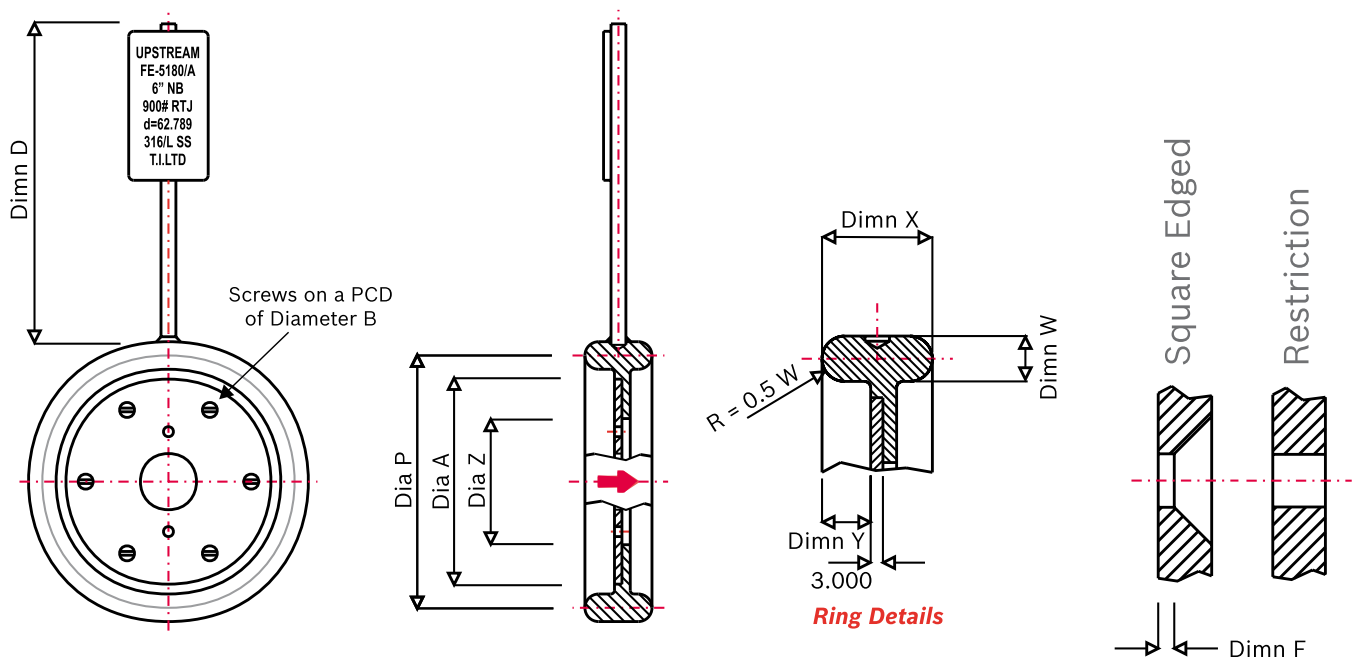

Rating and Line Size (Inches)				Ring No.	DIA. P	DIMN W	DIMN X	DIMN Y	DIA Z	DIMN F	DIA A	DIA B	DIMN D
300 # 600 #	900 #	1500 #	2500 #										
1	1	1		R 16	50.8	7.9	23.8	10.3	25.4	0.5	41.3	33.3	125
			1	R 18	60.2	7.9	23.8	10.3	25.4	0.5	41.3	33.3	150
1.5	1.5	1.5		R 20	68.3	7.9	23.8	10.3	38.1	0.5	54	46	125
			1.5	R 23	82.5	11.1	27	10.3	38.1	0.5	54	46	150
2				R 23	82.5	11.1	27	11.9	50.8	0.75	69.8	60.3	125
	2	2		R 24	95.3	11.1	27	11.9	50.8	0.75	82.55	66.6	150
			2	R 26	101.6	11.1	27	11.9	50.8	0.75	82.55	66.6	150
2.5				R 26	101.6	11.1	27	11.9	63.5	0.75	85.5	69.5	125
	2.5	2.5		R 27	107.9	11.1	27	11.9	63.5	0.75	91.8	75.8	150
			2.5	R 28	111.1	12.7	27	11.9	63.5	0.75	93.4	77.4	150
3	3			R 31	123.8	11.1	27	11.9	76.2	1	107.9	92	150
			3	R 32	127	12.7	28.6	12.7	76.2	1	107.9	92	150
		3		R 35	136.5	11.1	27	11.9	76.2	1	107.9	92	150
4	4			R 37	149.2	11.1	27	11.9	104	1.5	136.5	120.6	150
			4	R 38	157.2	15.9	31.7	14.3	104	1.5	136.5	120.6	150
		4		R 39	162	11.1	27	11.9	104	1.5	136.5	120.6	150
6	6			R 45	211.1	11.1	27	11.9	158.7	1.5	190.5	174.6	150
		6		R 46	211.1	12.7	34.9	12.7	158.7	1.5	190.5	174.6	150
			6	R 47	228.6	19.1	27	15.9	158.7	1.5	190.5	174.6	175
8	8			R 49	269.9	11.1	27	11.9	209.5	3.5	241.3	225.4	175
		8		R 50	269.9	15.9	31.7	14.3	209.5	3.5	241.3	225.4	175
			8	R 51	279.4	22.2	38.1	17.5	209.5	3.5	241.3	225.4	175
10	10			R 53	323.8	11.1	27	11.9	260.3	3.5	292.1	276.2	175
		10		R 54	323.8	15.9	31.7	14.3	260.3	3.5	292.1	276.2	175
			10	R 55	342.9	28.6	46	21.4	260.3	3.5	292.1	276.2	200
12	12			R 57	381	11.1	27	11.9	311.2	3.5	342.9	327	175
		12		R 58	381	22.2	38.1	17.5	311.2	3.5	342.9	327	175
			12	R 60	406.4	31.7	49.2	23	311.2	3.5	342.9	327	200
14 OD				R 61	419.1	11.1	27	11.9	343	5	374.6	358.8	150
	14 OD			R 62	419.1	15.9	31.7	14.3	343	5	374.6	358.8	175
		14 OD		R 63	419.1	25.4	27	19.8	343	5	374.6	358.8	175
16 OD				R 65	469.9	11.1	27	11.9	393.7	5	425.4	409.6	150
	16 OD			R 66	469.9	15.9	31.7	14.3	393.7	5	425.4	409.6	200
		16 OD		R 67	469.9	28.6	46	21.4	393.7	5	425.4	409.6	200
18 OD				R 69	533.4	11.1	27	11.9	444.5	5	476.2	460.4	175
	18 OD			R 70	533.4	19.1	34.9	15.9	444.5	5	476.2	460.4	200
		18 OD		R 71	533.4	28.6	46	21.4	444.5	5	476.2	460.4	200
20 OD				R 73	584.2	12.7	28.6	12.7	495.3	8	517.5	501.6	175

Standard Orifice Plate and Ring Dimensions

# Orifice Carrier Assemblies

- Design to BS EN ISO 5167
- Range of Carrier Types
  - Single Ring, Corner Tappings
  - Double Ring, Flange Tappings
  - Double Ring, Corner Tappings
  - Double Ring, Annular Chambers
- Wide range of materials
- Proven technology
- Suitable for 1" lines and above
- Orifice sizing on request

## General Description

The orifice plate is the most common differential pressure flow primary element. It is based on proven technology, has no moving parts and is suitable for high temperature and pressure applications. Orifice plates are recommended for clean liquids, gases and low velocity steam flows. Flow measurement using orifice plates requires the accurate location of upstream and downstream pressure tappings. Various types of orifice carrier assemblies are available to suit a wide range of applications.

Orifice flange assemblies in accordance with ANSI B16.36 are also available. Refer to page 13 for further details.

## Pressure Connections

The style of the pressure tappings may be as follows:-

- (a) **Flange Tappings** - located 25.4 mm upstream and 25.4 mm downstream from the corresponding face of the orifice plate.
- (b) **Corner Tappings** - single tappings located flush with the upstream and downstream faces of the orifice plates.
- (c) **Annular Chambers** - slots located flush with the upstream and downstream faces of the orifice plate.

Flange tappings are recommended for general applications. Corner tappings or annular chambers are particularly recommended for use in small lines (less than 50 mm diameter) and when the orifice plate is either of quarter circle, conical entrance or eccentric in design.



## Pressure Tapping Orientation

For vapours, dirty or condensable gases in a horizontal line, the tappings should be located at the side of the pipe, with no more than a  $\pm 45^\circ$  orientation from the horizontal.

### Horizontal

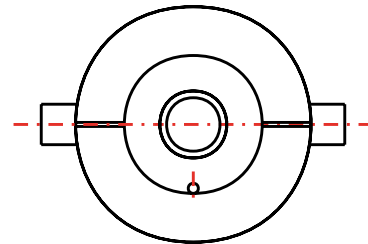

For liquid flows in a horizontal pipe the tappings should be in the lower half of the pipe, with no more than a  $\pm 45^\circ$  orientation from the horizontal.

### Inclined Down

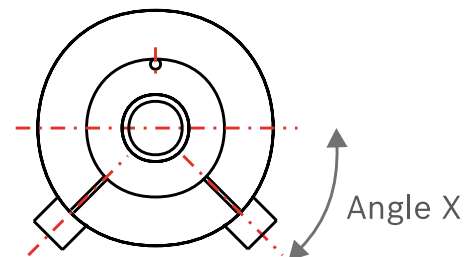

For horizontal clean gas flows, the tappings should be in the upper half of the pipe, with no more than a  $\pm 45^\circ$  orientation from the vertical.

### Inclined Up

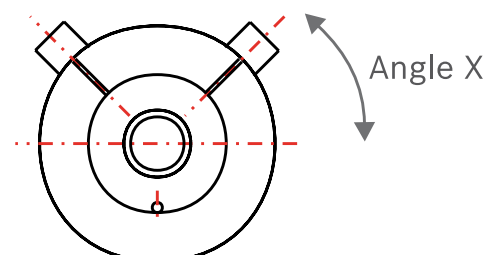

For vertical pipe installations, the pressure taps can be at any radial position around the pipe circumference.

### Double Ring Orifice Carriers

Double ring orifice carrier are designed to be mounted between standard pipe flanges. Versions are available to suit all common flange standards, including ANSI B16.5.

Double ring orifice carriers may be provided with flange tappings, single corner tappings or annular chambers.

Double ring orifice carriers use a standard tab handled

plate, which allows for easy replacement of the plate if it is damaged, or changes in process data necessitate a change of orifice bore.

Standard material of construction is 316L Stainless Steel, but a wide range of alternative common and exotic materials are available. Gaskets are provided - 1.5 mm thick non asbestos type, unless requested otherwise.

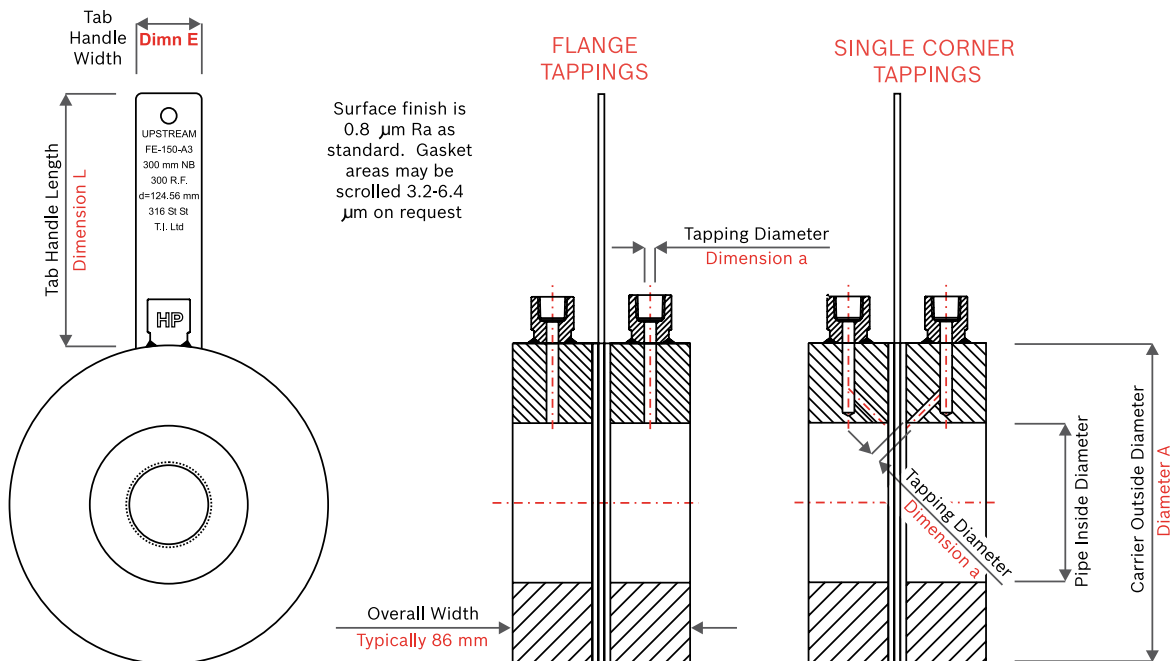

Line Size		150 LB			300 LB			600 LB			900 LB			1500 LB			Pressure Tapping Diameter a	
mm	IN	A	L	E	A	L	E	A	L	E	A	L	E	A	L	E	Flange	Cover
25	1	66.7	125	32	73	125	32	73	125	32	79.4	125	32	79.4	125	32	3	1
30	1 1/4	76.2			82.6			82.6			88.9			88.9				
40	1 1/2	85.7			95.3			95.3			98.4			98.4			5	
50	2	104.8			111.1		28	111.1		28	142.9	150		142.9	150		6	
65	2 1/2	123.8			130.2		32	130.2		32	165.1			165.1				1.25
80	3	136.5			149.2			149.2			168.3			174.6				1.5
100	4	174.6	150		181	150		193.7	150		206.4			209.6				2
125	5	196.9			215.9			241.3			247.7			254				2.5
150	6	222.3			250.8			266.7			288.9			282.6				3
200	8	279.4			308			320.7			358.8	175		352.4	175			4
250	10	339.7			362			400			435			435			10	5
300	12	409.6			422.3			457.2			498.5			520.7				6
350	14	450.9			485.8			492.1			520.7			577.9				7
400	16	514.4			539.8			565.2			574.7	200		641.4	200			8
450	18	546.1	175		593.7	175		609.6	175		635			701.7				9
500	20	603.3			650.9			679.5			695.3			752.5				10

### Annular Chamber Orifice Carriers

Annular chamber type orifice carriers are a special form of corner tappings. The annular slots break through to the pipe over the entire perimeter.

The table below shows typical dimensions for some common sizes. Versions to suit other flange sizes and ratings are available on request.

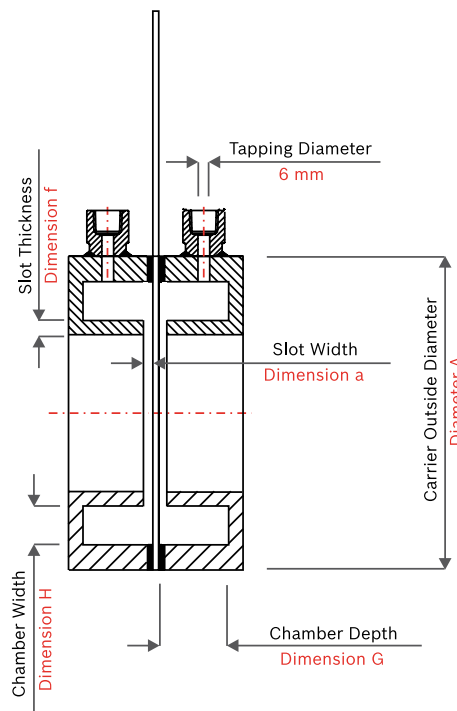
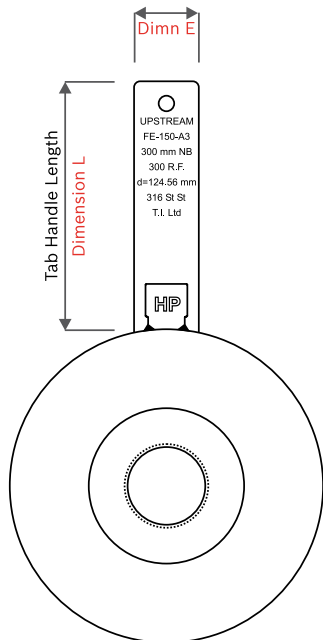

Surface finish is 0.8  $\mu\text{m Ra}$  as standard. Gasket areas may be scrolled 3.2-6.4  $\mu\text{m}$  on request

Nominal Size		150 LB			300 LB			600 LB			Dimension	
		OD	Chamber		OD	Chamber		OD	Chamber		a	f
mm	Inches	A	G	H	A	G	H	A	G	H		
25	1	66.7	10	12	73	10	12	73	10	12	1	2
30	1 1/4	76.2	10	12	82.6	10	12	82.6	10	12	1	2
40	1 1/2	85.7	12	12	95.3	12	12	95.3	12	12	1	2
50	2	104.8	12	12	111.1	12	12	111.1	12	12	1	2
65	2 1/2	123.8	15	12	130.2	15	12	130.2	15	12	1	2
80	3	136.5	18	12	149.2	18	12	149.2	18	12	1.5	3
100	4	174.6	20	20	181	20	20	193.7	20	20	1.5	3
125	5	196.9	25	20	215.9	25	20	241.3	25	20	1.5	3
150	6	222.3	26	20	250.8	26	20	266.7	26	20	1.75	3.5
200	8	279.4	33	23	308	28	30	320.7	28	30	2.25	4.5

### Single Ring Orifice Carriers

The single ring orifice carrier is a simple, compact orifice carrier, which may be machined in one piece, or be provided with a screwed-on plate. This carrier occupies the minimum of space between the pipeline flanges.

Standard material of construction is 316L Stainless Steel.

Due to its small thickness, the single ring orifice carrier is often a cost effective solution, and may be manufactured in a wide range of exotic materials including Hastelloy®, Monel®, Duplex Stainless Steel, Inconel® and Incoloy®

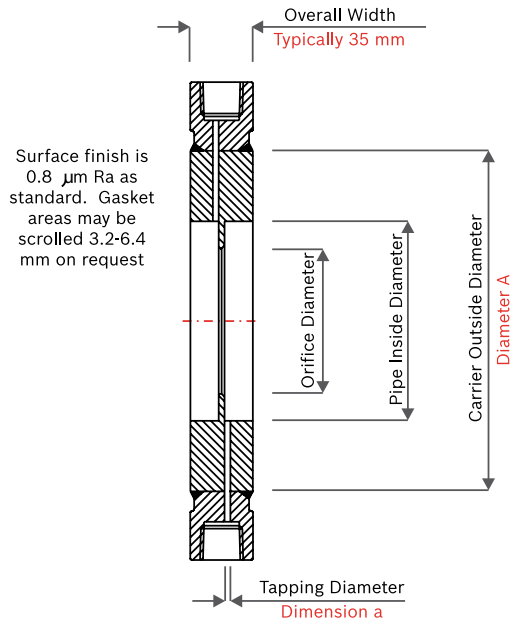
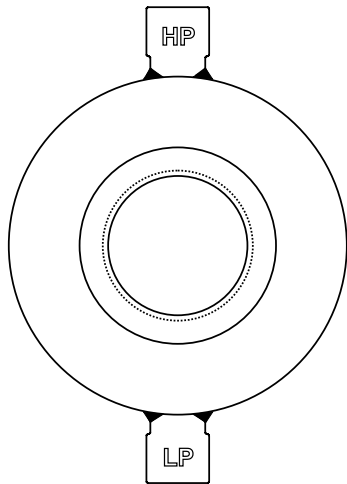

Nominal Line Size		150 LB		300 LB		600 LB		900 LB		1500 LB		2500 LB		Tapping Diameter
mm	Inches	A	X	A	X	A	X	A	X	A	X	A	X	a
25	1	66.7	-	73	-	73	-	79.4	-	79.4	-	85.7	-	1
30	1 1/4	76.2	-	82.6	-	82.6	-	88.9	-	88.9	-	104.8	-	1
40	1 1/2	85.7	-	95.3	-	95.3	-	98.4	-	98.4	-	117.5	-	1
50	2	104.8	-	111.1	45	111.1	45	142.9	45	142.9	45	146	45	1
65	2 1/2	123.8	-	130.2	45	130.2	45	165.1	45	165.1	45	168.3	45	1.25
80	3	136.5	-	149.2	45	149.2	45	168.3	45	174.6	45	196.9	45	1.5
100	4	174.6	45	181	45	193.7	45	206.4	45	209.6	45	235	45	2
125	5	196.9	45	215.9	45	241.3	45	247.7	45	254	45	279.4	45	2.5
150	6	222.3	45	250.8	30	266.7	30	288.9	30	282.6	30	317.5	45	3
200	8	279.4	45	308	30	320.7	30	358.8	30	352.4	30	387.4	30	4
250	10	339.7	30	362	45	400	45	435	45	435	30	476.3	30	5
300	12	409.6	30	422.3	45	457.2	36	498.5	36	520.7	45	549.3	30	6
350	14	450.9	30	485.8	36	492.1	36	520.7	36	577.9	45	-	-	7
400	16	514.4	45	539.8	36	565.2	36	574.7	36	641.4	45	-	-	8
450	18	546.1	45	593.7	30	609.6	36	635	36	701.7	45	-	-	9
500	20	603.3	36	650.9	30	679.5	30	695.3	36	752.5	45	-	-	10

Single orifice carriers to suit PN rated flanges and other flange standards are also available

# ANSI B16.36 Orifice Flanges

- **Wide range of materials, including**
  - ASTM A105N Carbon Steel
  - ASTM A350 LF2 Carbon Steel
  - ASTM A182 F316L Stainless Steel
- **Ratings from 300 lb to 2500 lb**
- **Sizes from 1" Nominal Bore**
- **Corner Tapping Versions Available**

## General Description

Orifice flanges are intended for use instead of standard pipe flanges when an orifice plate or flow nozzle must be installed. Pairs of pressure tapings are machined into the orifice flange, making separate orifice carriers or tapings in the pipe wall unnecessary.

The range of orifice flanges covers all standard sizes and ranges, and all common flange materials. Flanges are available in socket weld or weld neck form, and are typically supplied with two ½" NPT tapings in each flange. Jacking screws to ensure ease of removal of the primary flow element are provided.

Orifice plates and flow nozzles can also be supplied. See individual Product Data Sheets for more information.

Orifice flanges may also be supplied complete with bolting and gasket kits.

## Materials

We can supply orifice flanges in a wide range of standard and special materials, including:

- ASTM A105 Carbon Steel
- ASTM A350 LF2 Low Temp Carbon Steel
- ASTM A182 F316 Stainless Steel
- ASTM A182 F304 Stainless Steel
- ASTM A182 F11 1¼% Cr ½% Mo
- ASTM A182 F22 2¼% Cr 1% Mo

## Pressure Tapings

As standard, two ½" NPT tapings are provided in each flange, one with a plug. Other thread sizes are available on request. Socket weld connections may be specified, and butt weld pipe nipples are also available. Tapings are generally 'flange' type, but corner tapings are optional.

## Gaskets

A range of suitable gaskets for use with orifice flanges is also available.

Typical specifications include:

- 1.5 mm thick IBC ring type, non asbestos
- 3.2 mm thick spiral wound type, carbon steel outer, stainless steel inner, 316L windings with graphite filler



*Orifice Flange Assembly*

## Studbolts and Nuts

Suitable bolting may be supplied on request. Standard materials include:

- ASTM A193 B7 and ASTM A194 Gr 2H
- ASTM A320 L7 and ASTM A194 Gr 4 or 7
- ASTM A320 B8 and ASTM A194 Gr 8

Bolting conforming to NACE is also available.



## Weldneck Orifice Flange Assemblies

Weldneck orifice flanges are butt-welded into the pipeline. The inside diameter (or the schedule) of the pipe should be specified when ordering.

Weldneck orifice flanges are available in classes 300, 600, 900, 1500 and 2500. Raised face (RF) and ring type joint (RTJ) versions can be supplied.

Please refer to page 7 for details of orifice plates with RTJ holders.

Bolt sizes, weights and important dimensions of orifice flange assemblies are shown in the following tables.

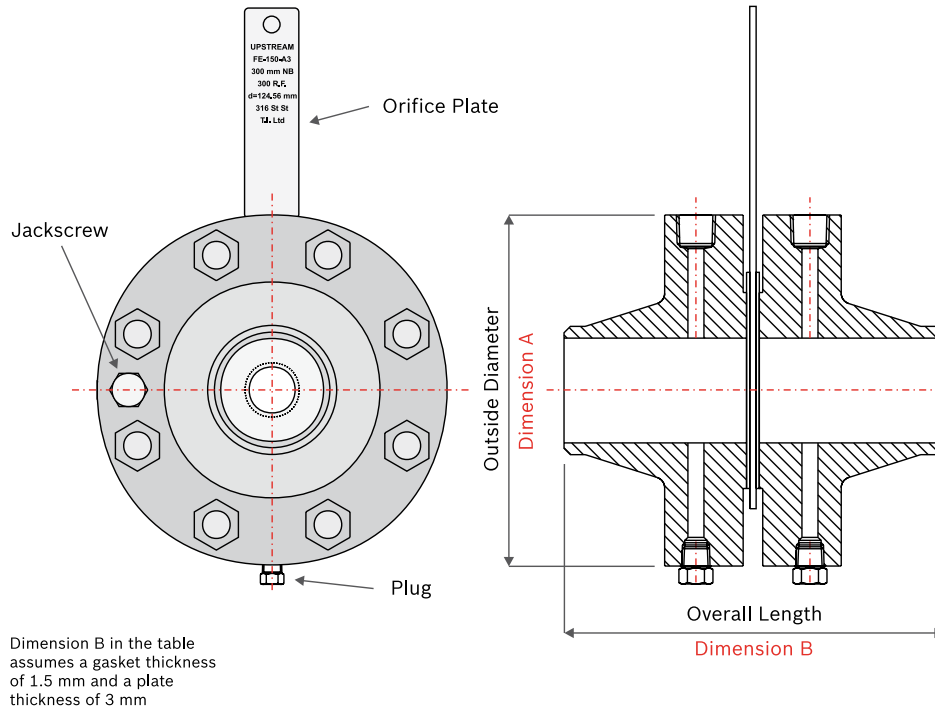

Nominal Size		Weldneck Orifice Flanges - 300 lb RF				
		Bolts		Approx. weight (kg)	Dimensions	
mm	Inches	Bolt Qty	Bolt Sizes		B	A
25	1	4	5/8" x 5.00"	9	171	124
40	1 1/2	4	3/4" x 5.25"	13	178	155
50	2	8	5/8" x 5.00"	14	178	165
65	2 1/2	8	3/4" x 5.25"	18	184	191
80	3	8	3/4" x 5.25"	21	184	210
100	4	8	3/4" x 5.25"	31	190	254
150	6	12	3/4" x 5.25"	50	206	318
200	8	12	7/8" x 5.75"	73	229	381
250	10	16	1" x 6.50"	100	241	445
300	12	16	1 1/8" x 7.00"	151	266	521
350	14	20	1 1/8" x 7.25"	207	291	584
400	16	20	1 1/4" x 7.75"	275	298	648
450	18	24	1 1/4" x 8.00"	341	324	711
500	20	24	1 1/4" x 8.50"	408	330	775
600	24	24	1 1/2" x 9.50"	604	342	914

Nominal Size		Weldneck Orifice Flanges - 600 lb RF				
		Bolts		Approx. weight (kg)	Dimensions	
mm	Inches	Bolt Qty	Bolt Sizes		B	A
25	1	4	5/8" x 5.00"	9	171	124
40	1 1/2	4	3/4" x 5.25"	13	178	155
50	2	8	5/8" x 5.00"	14	178	165
65	2 1/2	8	3/4" x 5.25"	18	184	191
80	3	8	3/4" x 5.25"	21	184	210
100	4	8	7/8" 6.00"	41	209	273
150	6	12	1" x 7.00"	82	241	356
200	8	12	1 1/8" x 7.75"	124	273	419
250	10	16	1 1/4" x 8.75"	208	311	508
300	12	20	1 1/4" x 9.00"	250	317	559
350	14	20	1 3/8" x 9.50"	-	336	603
400	16	20	1 1/2" x 10.25"	-	362	686
450	18	20	1 5/8" x 11.00"	-	374	743
500	20	24	1 5/8" x 11.75"	-	387	813
600	24	24	1 7/8" x 13.25"	-	412	940

Nominal Size		Weldneck Orifice Flanges - 900 lb RF				
		Bolts		Approx. weight (kg)	Dimensions	
mm	Inches	Bolt Qty	Bolt Sizes		B	A
25	1	4	7/8 x 6.00"	13	171	149
40	1 1/2	4	1" x 6.25"	18	184	178
50	2	8	7/8" x 6.00"	29	209	216
65	2 1/2	8	1" x 6.50"	41	215	244
80	3	8	7/8" x 6.00"	34	209	241
100	4	8	1 1/8" x 7.00"	59	235	292
150	6	12	1 1/8" x 7.75"	120	285	381
200	8	12	1 3/8" x 9.00"	204	330	470
250	10	16	1 3/8" x 9.50"	291	374	546
300	12	20	1 3/8" x 10.25"	405	406	610
350	14	20	1 1/2" x 11.00"	-	431	641
400	16	20	1 5/8" x 11.50"	-	438	705
450	18	20	1 7/8 x 13.00"	-	463	787
500	20	20	2" x 14.00"	-	501	857
600	24	20	2 1/2" x 17.50"	-	590	1041

Nominal Size		Weldneck Orifice Flanges - 1500 lb RF				
		Bolts		Approx. weight (kg)	Dimensions	
mm	Inches	Bolt Qty	Bolt Sizes		B	A
25	1	4	7/8 x 6.00"	13	171	149
40	1 1/2	4	1" x 6.25"	18	184	178
50	2	8	7/8" x 6.00"	29	209	216
65	2 1/2	8	1" x 6.50"	41	215	244
80	3	8	1 1/8" x 7.25"	58	241	267
100	4	8	1 1/4" x 8.00"	82	254	311
150	6	12	1 3/8" x 10.50"	186	349	394
200	8	12	1 5/8" x 11.75"	306	432	483
250	10	12	1 7/8" x 13.50"	500	514	584
300	12	16	2" x 15.00"	764	571	673
350	14	16	2 1/4" x 16.25"	-	603	749
400	16	16	2 1/2" x 17.75"	-	628	826
450	18	16	2 3/4" x 19.75"	-	660	914
500	20	16	3" x 21.50"	-	717	984
600	24	16	3 1/2" x 24.50"	-	819	1168

## Slip-On Orifice Flange Assemblies

Slip-on orifice flanges are designed to slip over the pipe-line before welding.

Slip-on orifice flanges are available in class 300, with a raised face (RF).

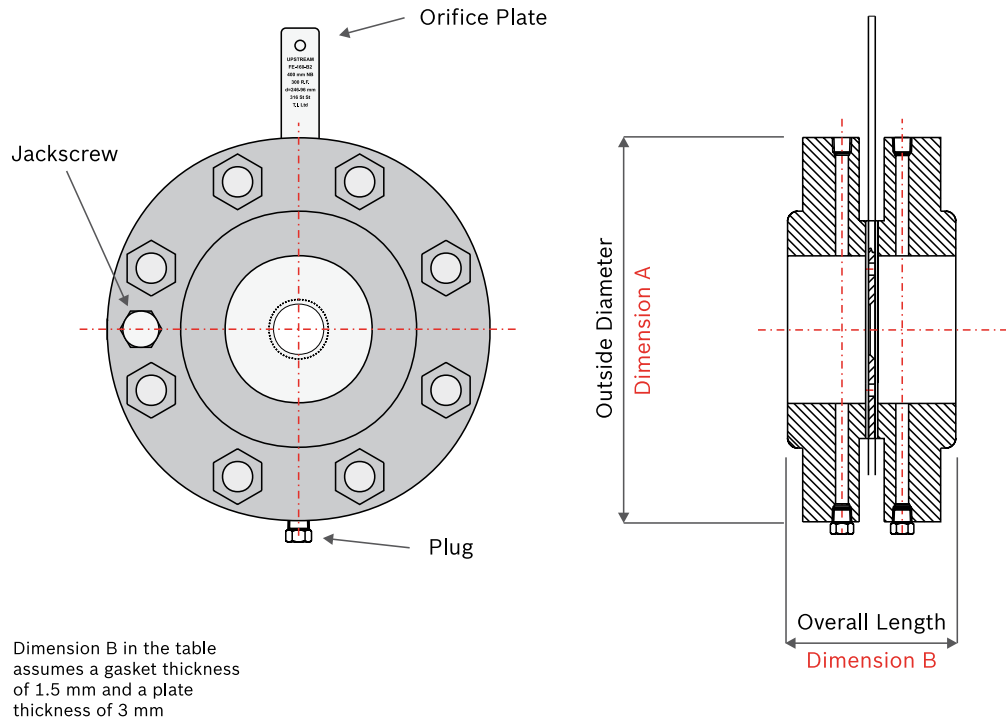

Nominal Size		Slip-On Orifice Flanges - 300 lb RF				
		Bolts		Approx. weight (kg)	Dimensions	
mm	Inches	Bolt Qty	Bolt Sizes		B	A
25	1	4	5/8" x 5.00"	7.5	102	124
40	1 1/2	4	3/4" x 5.25"	9.3	102	155
50	2	8	5/8" x 5.00"	11.5	105	165
65	2 1/2	8	3/4" x 5.25"	15	108	191
80	3	8	3/4" x 5.25"	19	111	210
100	4	8	3/4" x 5.25"	29	114	254
150	6	12	3/4" x 5.25"	50	114	318
200	8	12	7/8" s 5.75"	65	130	381
250	10	16	1" x 6.50"	91	139	445
300	12	16	1 1/8" x 7.00"	133	152	521
350	14	20	1 1/8" x 7.25"	177	158	584
400	16	20	1 1/4" x 7.75"	240	171	648
450	18	24	1 1/4" x 8.00"	323	184	711
500	20	24	1 1/4" x 8.50"	360	197	775
600	24	24	1 1/2" x 9.50"	555	219	914

# DPCalc - Flow Element Sizing Software

- Designed for use with Windows® 95, 98, NT and XP
- Calculations to BS EN ISO 5167:1 and BS 1042 1.2
- Orifice Plates, Flow Nozzels and Venturis
- A.I.Ch.E. Fluid property data for over 70 common fluids
- ASME 1967 Steam Density Tables
- Solve for Orifice/Throat Diameter, Flow or Differential Pressure
- Comprehensive selection of units of measurement

## General Description

DPCalc is a true 32-bit Windows solution to differential pressure flow metering calculations. Based on the latest revision of BS EN ISO 5167:1, DPCalc allows the user to accurately calculate orifice diameter, flow rate or differential pressure.

Ease of use is enhanced by a built in database of fluid properties for over 80 common fluids, saving a great deal of time and effort in calculating or looking up values in tables. Internal pipe tables are included enabling internal diameter to be calculated from nominal bore and schedule. Calculation of expansion coefficients for many common pipe and flow element materials is also included.

For each variable, an extensive list of metric and imperial units of measurement is available.

Calculated results include unrecovered pressure loss, an uncertainty analysis, and a series of checks to ensure conformance with the requirements of BS EN ISO 5167:1.

Results can be printed to any Windows printer, or saved to disk for future reference.

## System Requirements

PC with a 486/66 MHz or higher processor: Pentium Recommended  
 Microsoft® Windows® 95 or later operating system or Microsoft® Windows® NT Workstation operating system version 4.0 or higher  
 16 MB RAM / 10 MB Hard Disk Space (Maximum)  
 CD ROM Drive  
 SVGA Monitor (800 x 600 resolution, 256 colours)  
 Mouse or other pointing device

## Supported Flow Elements

The following flow measuring primary elements are supported in DPCalc:-

- Orifice Plate, Flange Tappings
- Orifice Plate, Corner Tappings
- Orifice Plate, D & D/2 Tappings
- ISA 1932 Flow Nozzle
- ASME Long Radius Flow Nozzle
- Venturi, Machined Convergent Section
- Venturi, As Cast Convergent Section
- Venturi, Fabricated Convergent Section
- Venturi Nozzle
- Quarter Circle Orifice Plate
- Conical Entrance Orifice Plate

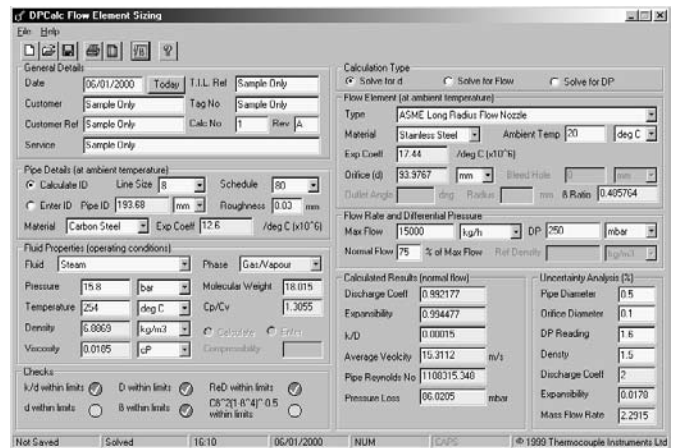

DPCalc Screenshot

- Eccentric Orifice Plate
- Orifice Plate, 25mm -50mm Lines

Note the Restriction Orifice Plates are not included (as the calculation method is not described by BS EN ISO 5167:1). A separate program for this is available, ROCalc (please refer to the relevant data sheet).

## Printing

Results may be printed on any Windows® printer, on A4 paper.

A sample of the printed page is shown below.

<b>Flow Element Sizing Calculation</b> In accordance with BS EN ISO 5167-1 and BS 1042 1.2			
<b>GENERAL DETAILS</b>			
Date	06/01/2000	Thermocouple Ref	Sample Only
Customer Name	Sample Only	Calculation Number	1 Rev 0
Customer Ref	Sample Only	Tag Number	Sample Only
Service	Sample Only		
<b>PIPE DETAILS (AT AMBIENT TEMPERATURE)</b>			
Nominal Line Size	6	Exact Pipe ID	146.34 mm
Schedule	80	Surface Roughness	0.03 mm
Pipe Material	Chrome-Moly	Coefficient of Expansion	12.62 E-06 /deg C
<b>FLOW ELEMENT DETAILS</b>			
Element Type	ISA 1932 Flow Nozzle		
Element Material	Stainless Steel	Coefficient of Expansion	17.45 E-06 /deg C
Ambient Temperature	20 deg C	Bleed Hole Diameter	0 mm
β Ratio	0.589334	Orifice/Throat Diameter	86.1444 mm
Outlet Angle	N/A	Radius	N/A
<b>FLOW RATE AND DIFFERENTIAL PRESSURE</b>			
Meter Max Flow Rate	12500 kg/h	Normal Flow Rate	9375 kg/h
Differential Pressure	250 mbar	Reference Density	N/A
<b>PROCESS CONDITIONS</b>			
Fluid Name	Steam	Fluid State	Gas/Vapour
Operating Pressure	14.5 barg	Operating Temperature	258 deg C
Operating Density	6.6898 kg/m3	Operating Viscosity	0.0186 cP
Isentropic Exponent	1.305	Molecular Weight	18.015
Compressibility	N/A		
<b>CALCULATED RESULTS (AT NORMAL FLOW RATE)</b>			
Discharge Coefficient	0.963927	Expansibility Coefficient	0.993835
Relative Roughness	0.0002	Average Velocity	23.0056 m/s
Pipe Reynolds Number	1211844.377	Pressure Loss	66.6321 mbar
<b>UNCERTAINTY ANALYSIS</b>			
Pipe Diameter	0.5 %	Orifice Diameter	0.1 %
DP Reading	1.6 %	Density	1.5 %
Discharge Coefficient	0.8 %	Expansibility Coefficient	0.0181 %
Mass Flow Rate	1.3832 %		
<b>ERROR MESSAGES</b>			
No errors to report			
E-mail <a href="mailto:thermocouple@thermocouple.co.uk">thermocouple@thermocouple.co.uk</a> Internet <a href="http://www.thermocouple.co.uk">www.thermocouple.co.uk</a>			
Calculation produced by DPCalc® Version 1.0.0. DPCalc® software is a product of Thermocouple Instruments			

### On-Line Help

On line help is extensive and informative, providing assistance both in the use of the software and in the selection of the correct flow element for the application.

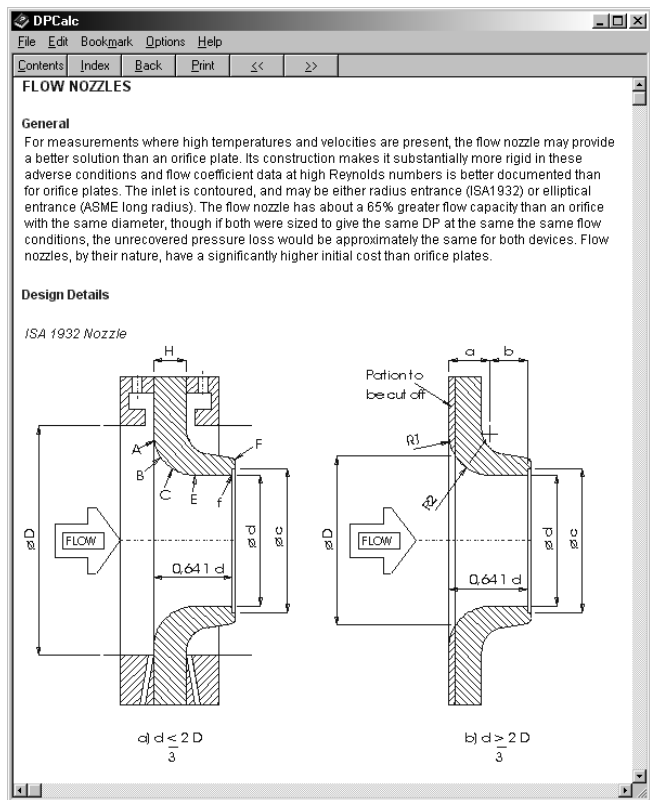

Sample Help Screen

### Fluid Property Data

For many common fluids the following fluid properties can be computed, given the operating temperature and pressure:-

- Density
- Viscosity
- Molecular Weight (gases/vapours only)
- Compressibility (gases/vapours only)
- Isentropic Exponent (gases/vapours only)

Values are computed in accordance with formulae presented by the A.I.Ch.E. (Note that steam density is calculated using the ASME 1967 formulation).

At pressures and temperatures where data cannot be calculated, DPCalc's comprehensive error handling facility informs the user of the problem, and suggests solutions where possible.

For fluids not in the database, 'Liquid' or 'Gas' can be selected, and values of fluid properties entered manually. A list of the fluids included in the database is shown below.

- Nitrogen(N2), Oxygen(O2), Hydrogen(H2),
- Water(H2O), Carbon Monoxide(CO),
- Carbon Dioxide(CO2), Methane(CH4), Air,
- Argon(Ar), Acetic Acid(C2H4O2), Acetylene(C2H2),
- Ammonia(H3N), Benzene(C6H6), Propane(C3H8),
- Acetone(C3H6O), Hydrogen Sulphide(H2S),
- Sulphuric Acid(H2O4S), Silane(H4Si), Helium(He),
- Iodine(I2), Nitrogen Oxide(N2O), Neon(Ne),
- Sulphur Dioxide(O2S), Ozone(O3), Xenon(Xe),
- Sodium Hydroxide(HNaO), Fluorine(F2),
- Hydrogen, Fluoride(FH), Chlorine(Cl2),
- Hydrochloric Acid(ClH), Steam,
- Hexatriacontane(C36H74),
- Thionyl Chloride(Cl2OS), Sulphur Chloride(Cl2S),
- Trichlorosilane(Cl3HSi), Nitric Acid(HNO3),
- Krypton(Kr), Ethylene(C2H4), Ethane(C2H6),
- Propadiene(C3H4), Propylene(C3H6),
- 1-2-Butadiene(C4H6), Isobutene(C4H8),
- n-Butane(C4H10), Glycerol(C3H8O3),
- Isopentane(C5H12), Neopentane(C5H12),
- n-Hexane(C6H14), n-Nonane(C9H20),
- n-Decane(C10H22), n-Undecane(C11H24),
- n-Dodecane(C12H26), n-Tricosane(C23H48),
- n-Octacosane(C28H58), 1-Butene(C4H8),
- 1-Pentene(C5H10), 1-Hexene(C6H12),
- 1-Heptene(C7H14), 1-Octene(C8H16),
- Toluene(C7H8), m-Xylene(C8H10),
- o-Xylene(C8H10), p-Xylene(C8H10),
- Styrene(C8H8), Cumene(C9H12),
- Acetic Anhydride(C4H6O3),
- 3-Chloropropene(C3H5Cl), Benzoic Acid(C7H6O2),
- Butyl Acetate(C6H12O2), Carbon Disulphide(CS2),
- Carbon Tetrachloride(CCl4)

# Venturi Tubes and Venturi Nozzles

- **Classical Venturi Tubes**
- **Venturi Nozzles**
- **Calculation, Design and Manufacture to BS EN ISO 5167:1**
- **Fabricated from Plate or Machined from Bar/Forgings**
- **Flanged or Weld-In Construction**
- **Range of Material Grades**
- **Pipe Sizes from 50 mm to 1200 mm**
- **Calibration Service on Request**

## General Description

There are two common types of Venturi tube - the Venturi Nozzle, and the Classical (Herschel) Venturi. Both feature a convergent inlet section and a divergent outlet section. The classical Venturi convergent section is a simple truncated cone, whereas for the Venturi nozzle, the inlet contour matches that of the ISA 1932 flow nozzle.

The major advantage of the Venturi over orifice plates and flow nozzles is in the area of pressure recovery. Typically, unrecovered pressure is in the region of 10 - 30% of measured DP as opposed to 40 - 90% for an orifice plate (depending on beta ratio). Although the cost of a Venturi can be comparatively high, where pumping costs are important the initial outlay can be warranted.

Another advantage of the Classical Venturi over the other differential pressure producers is that the requirements for upstream and downstream straight pipe lengths are somewhat less onerous.

## Materials

Venturi tubes and Venturi nozzles can be supplied in a wide range of material grades.

Machined devices can be manufactured from barstock, or forgings. Standard materials include ASTM A182 F316 & F304 Stainless Steels, ASTM A182 F11 & F22 Chromium Steels and ASTM A105 Carbon Steel

Standard materials for fabricated devices are ASTM A240 316/L Stainless Steel and Carbon Steel.

We are experienced in machining and welding exotic materials, including Hastelloy®, Inconel®, Incoloy® and Duplex Stainless Steels.

*Incoloy, Inconel and Monel and are trademarks of INCO Alloys International Inc.*

*Hastelloy is a trademark of Haynes International Inc.*



300mm Fabricated Classical Venturi

## Dimensions

The basic design of the two types of device are shown below.

CLASSICAL VENTURI (MACHINED)

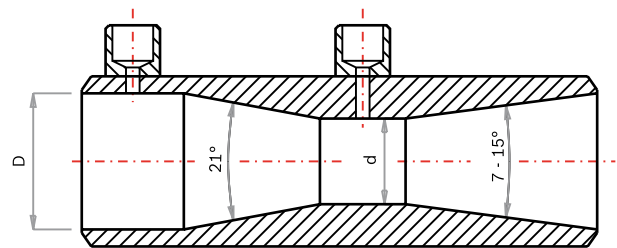

VENTURI NOZZLE (MACHINED)

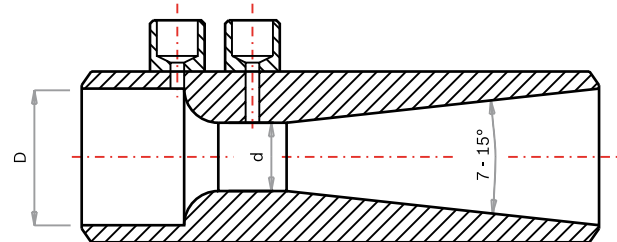

## End Connections

Venturis are available with ends prepared for welding into the pipeline, or fitted with flanges.

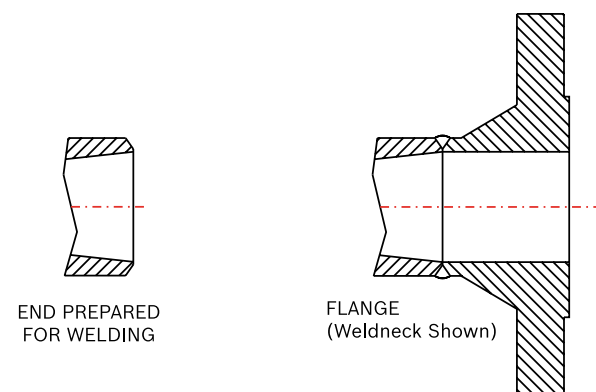

### Pressure Tappings

Venturis can be supplied with a wide variety of pressure tappings, including threaded connections, socket weld connections and welding nipples.

We can also supply isolation valves, condensate chambers and manifolds, as the application demands.

Examples of Pressure Tappings

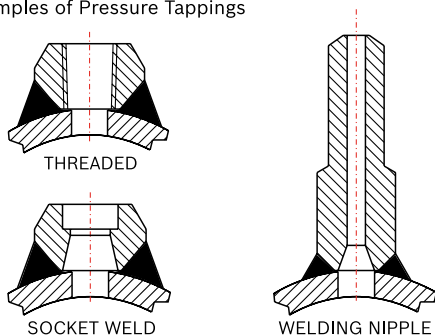

### Required Straight Lengths

Upstream straight pipe requirements for classical Venturi tubes are less than those required for orifice plates, flow nozzles and Venturi nozzles - the convergent portion of the classical Venturi is designed to obtain a more uniform velocity profile at the throat of the device.

The lengths shown in the table below, in terms of pipe diameters, are measured from the plane of the upstream pressure tapping.

Fittings located more than four throat diameters downstream of the plane of the throat tapping do not affect the accuracy of the measurement.

Diameter Ratio $\beta$	Single 90° bend	Two or more 90° bends in the same plane	Reducer 3D to D over a length of 3.5D	Expander 0.75D over a length of D	Full bore ball or gate valve fully open
0.30	8	8	2.5	2.5	2.5
0.35	8	8	2.5	2.5	2.5
0.40	8	8	2.5	2.5	2.5
0.50	9	10	5.5	2.5	3.5
0.60	10	10	8.5	3.5	4.5
0.70	14	18	10.5	5.5	5.5
0.75	16	22	11.5	6.5	5.5

### Limitations

Pipe size and Reynolds number limitations are shown in the table below, in accordance with BS EN ISO 5167:1.

Device	Pipe Inside Diameter (mm)		Reynolds Number	
	Min	Max	Min	Max
Fabricated Venturi	200	1200	$2 \times 10^5$	$2 \times 10^6$
Machined Venturi	50	250	$2 \times 10^5$	$1 \times 10^6$
Venturi Nozzle	65	500	$1.5 \times 10^5$	$2 \times 10^6$

### Unrecovered Pressure Loss

The graph below shows the advantage of Venturi tubes and Venturi nozzles over orifice plates and flow nozzles. Pressure loss is expressed as a percentage of the measured differential pressure.

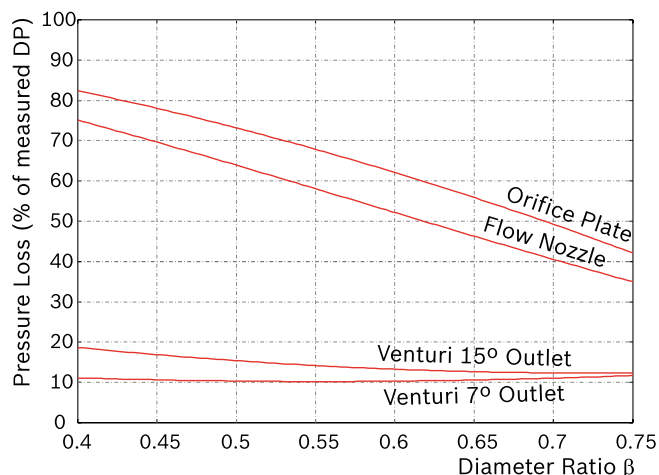

### Special Requirements

For applications requiring high accuracy flow measurement, Venturi tubes can be individually calibrated, using water, air or natural gas, to obtain accurate discharge coefficients for the device over a range of Reynolds numbers.

We can also offer 'in-house' testing including dye-penetrant inspection, hydrostatic pressure testing, radiographic inspection, magnetic particle inspection and positive material identification.

ASME IX welding procedures and qualifications in common and exotic materials are also available. Various heat treatments, including NACE MR 0175, can also be provided.

# Averaging Pitot Tubes

- Liquid, Gas and Steam Flow Measurement
- Low Installation Costs
- Long Term Accuracy
- Minimal Unrecovered Pressure Loss
- Suitable for Large Pipes and Ducts
- 'Hot-Tap' Versions Available
- Optional Integral Manifold
- Flow Transmitters Fitted
- Mass Flow Measurement

## General Description

The Averaging Pitot Tube is a differential pressure producer suitable for liquid, gas and steam flow measurement. It offers simple, low cost installation into pipes and ducts, and high energy savings due to its low unrecovered pressure loss. There are no moving parts or sharp edges to wear, so long term accuracy can be maintained.

'Hot-Tap' versions are available which allow the Averaging Pitot Tube to be withdrawn from the process whilst still under pressure.

Versions fitted with an optional manifold allow close mounting of differential pressure transmitters. For true mass flow measurement, a multivariable transmitter may be fitted.

## Specification

### Pipe Sizes

Standard Averaging Pitot Tubes can be provided to suit pipe sizes from 80 mm up to several metres in diameter. Flow in square and rectangular ducts may also be measured by Averaging Pitot Tubes. For small pipe sizes, in-line Pitot devices are available.

### Probe Diameter

Depending on pipe size and process conditions, probe diameters may be 13 mm, 25 mm or 60 mm (nominal).

### Materials

Averaging Pitot Tubes are provided in 316L Stainless Steel as standard. Other material grades are available to special order, including Duplex Stainless Steel, Monel® 400 and Hastelloy® C-276.

### Process Connection

Connections to the pipe may be either flanged or screwed. A wide choice of sizes and ratings are available.

### Impulse Connection

Averaging Pitot Tubes may be specified with a variety of impulse connections including threaded, socket weld or flanged. Primary isolation valves may also be supplied, appropriate to the process temperature and pressure.

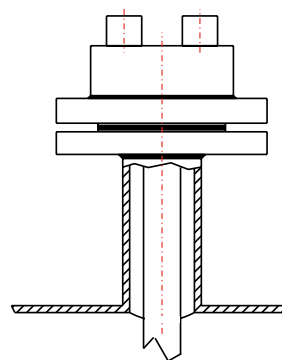
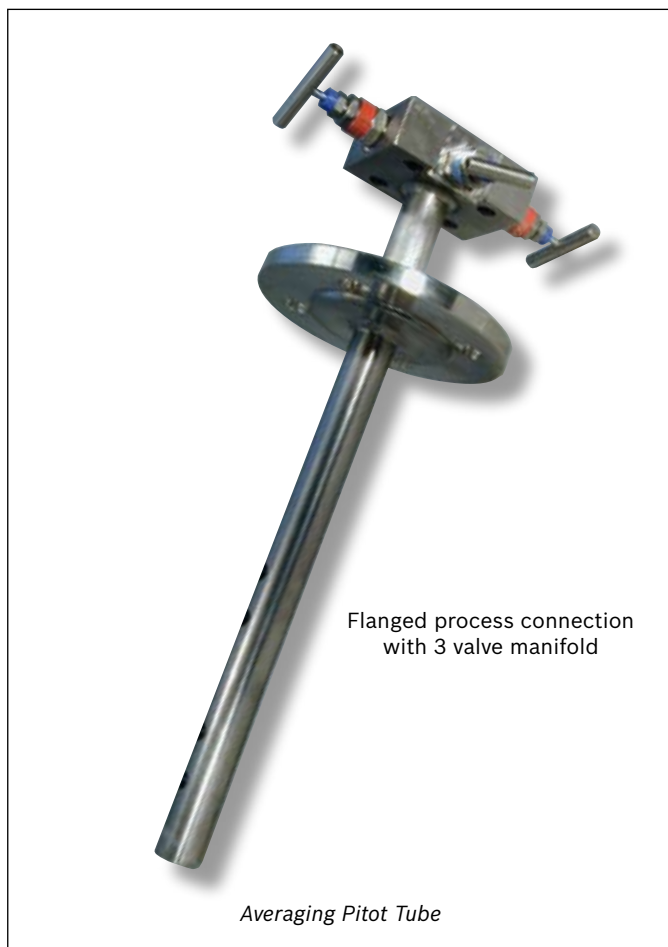

Flanged Process  
Connection

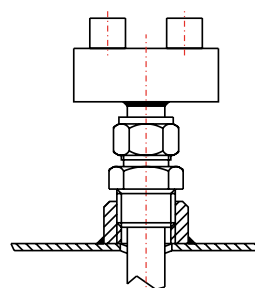

Screwed Process  
Connection

## Opposite Supports

When fluid flows past an Averaging Pitot Tube, vortices form at both sides of the probe. These vortices detach, first from one side, and then from the other. This phenomenon is known as the Von Karmann effect. The frequency of shedding of these vortices is a function of the diameter of the Pitot Tube, the fluid velocity and, to a lesser extent, the Reynolds number. The vortex shedding subjects the Pitot Tube to a periodic transverse force. As the vortex shedding frequency approaches the natural frequency of the Pitot Tube, it will oscillate, and is liable to snap off. This effect is taken into account when designing the Pitot Tube.

When the natural frequency of the Averaging Pitot Tube coincides with the vortex shedding frequency a lower support may be used to counteract these effects. Opposite supports can be provided in any material in line with the pipe specification.

The graph below gives some general guidance as to the flowing velocities to be avoided. All Averaging Pitot Tubes are provided with a wake frequency calculation as standard.

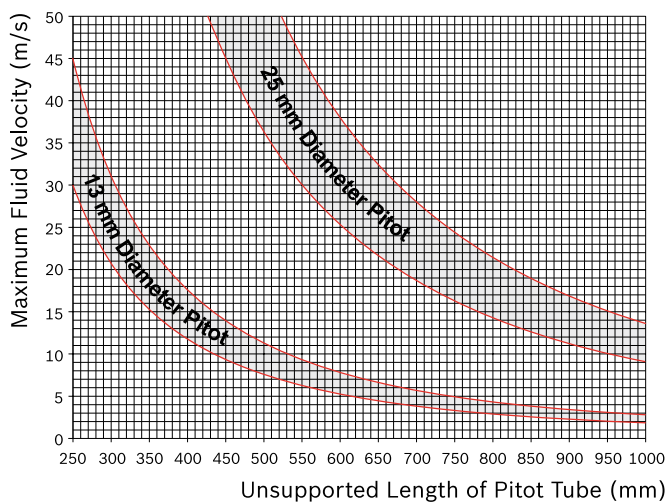

## Method of Fixing Opposite Support

The method of welding the opposite support into the pipe is shown in the figure below.

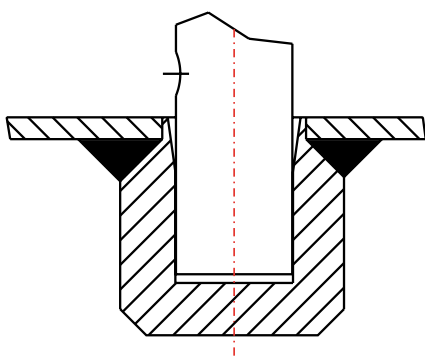

## Flow Calculations

Flow rate and differential pressure are related by a square root law of the form

$$\Delta P = \frac{1}{2} \frac{\rho \times v^2}{K^2}$$

where  $\Delta P$  is the generated differential pressure in Pascals,  $\rho$  is the density of the fluid at the operating conditions in  $\text{kg/m}^3$ ,  $v$  is the fluid velocity in  $\text{m/s}$  and  $K$  is the flow coefficient.

$K$  is constant over a wide Reynolds number range, and so the square root law is obeyed over a wide flow range.

## Meter Accuracy

Ideally installed in turbulent flowing conditions an accuracy of better than  $\pm 1.5\%$  is achievable over a flow range of 4:1. The flow turn-down is limited by the operating range and accuracy of the differential pressure transmitter. Repeatability is typically  $\pm 0.1\%$ , dependent on secondary instrumentation.

## Unrecovered Pressure Loss

Averaging Pitot Tubes present only a small obstruction to the flow, particularly when compared to orifice plates. Consequently, unrecovered pressure loss is low. The table below shows approximate values of unrecovered pressure loss, as a percentage of the measured differential pressure.

Line Size	Probe Diameter 25 mm	Probe Diameter 13 mm
50 mm	N/A	20
150 mm	10	5
250 mm	6	3
450 mm	4	1
750 mm	3	
1000 mm		Negligible

## Installation

Averaging Pitot Tubes must be installed at right angles to the pipe diameter.

Preferred mounting arrangements for gas, liquid and steam flow applications in horizontal pipes are shown below.

Averaging Pitot Tubes may also be used in vertical lines. In this instance, the location of the Pitot head may be at any angular position. Pitot tubes for installation in vertical lines may be specified with a head which is rotated through 90 degrees. This ensures that the DP connections are at the same level.

### Recommended Orientation

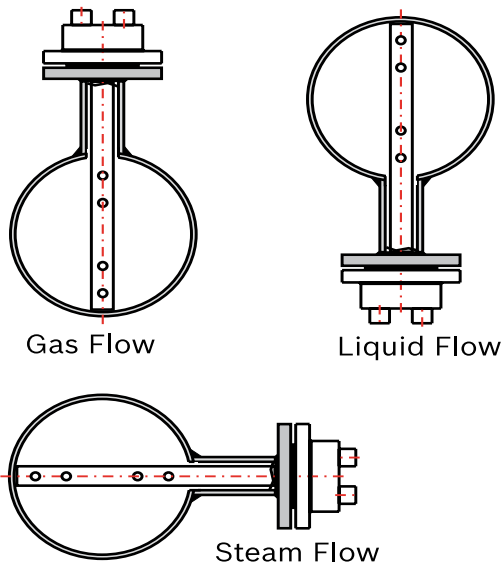

### Straight Pipe Lengths

In common with other differential pressure primary flow elements, Averaging Pitot Tubes require a well developed flow profile. Disturbances created by various pipe configurations can reduce measurement accuracy. Recommended upstream and downstream straight pipe lengths are shown below, in terms of multiples of the pipe diameter.

Averaging Pitot Tubes installed with shorter pipe lengths can still provide a repeatable flow measurement.

Upstream Disturbance	Upstream Diameters Pitot in Plane	Upstream Diameters Pitot out of Plane	Downstream Diameters
	5	7	3
	8	11	3
	12 In plane of last bend	18	4
	6	7	3
	15	18	4

### Integral Manifold Version

For applications requiring close mounting of the differential pressure transmitter, Averaging Pitot tubes may be provided with an integral 3 or 5 valve manifold. No impulse lines are required, reducing installation costs and improving response times.

Close mounting of the transmitter is not always possible, because of the temperature limitations of the transmitter (typically about 85°C). In such cases a remote mounting configuration is required.

### Hot-Tap Version

The 'Hot-Tap' versions allow the Averaging Pitot Tube to be withdrawn from the fluid under flowing conditions.

A gate or ball valve is used to allow sealing after removal. A pressure chamber prevents fluid leaking to atmosphere during removal through the averaging Pitot ports.

Flanged fitting is the preferred option for Hot-Tap Pitots.

The headworks are manufactured in stainless steel as standard, and handwheel operation is provided. Typically, at least three times the pipe diameter of headroom is required for clearance removal.

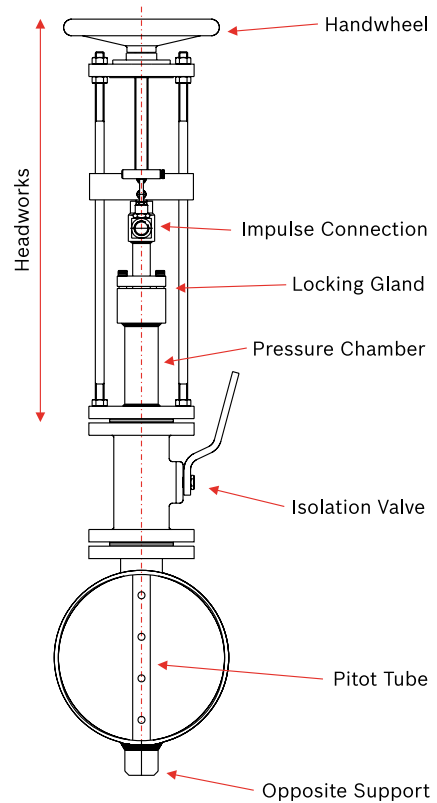

# Meter Runs

## General Description

Typically consisting of a factory assembled section of pipe with an orifice plate mounted between two flanges near the centre of the run, terminated with a flange at each end to connect to the process.

Building the assembly in the factory allows us to control all the variables which can lead to inaccuracies which can arise if the system is assembled by untrained personnel on-site.

The following points need to be carefully controlled; they can all lead to inaccuracies, particularly with small diameter pipes up to DN50 (2”).

1. Accurate upstream & downstream minimum pipe-lengths.
2. Correct selection and placement of tappings.
3. Control of the internal pipe smoothness.
4. Accurate machining of pipe bore adjacent to the plate.
5. Correct centering of the orifice plate.
6. Damage to orifice face and upstream edge during assembly / storage.
7. Correct fitting of gaskets to avoid partial blockage of the flow.

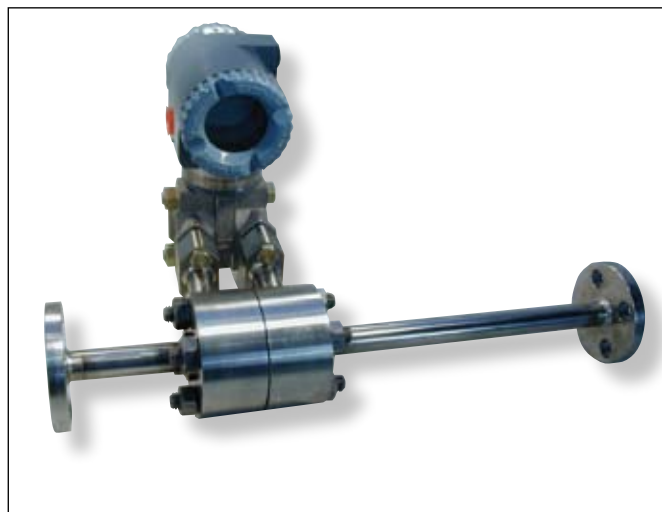

Other advantages include reduced installation time; the completed section only needs to be bolted into the pre-prepared line.

The complete assembly can be calibrated to provide the maximum accuracy.

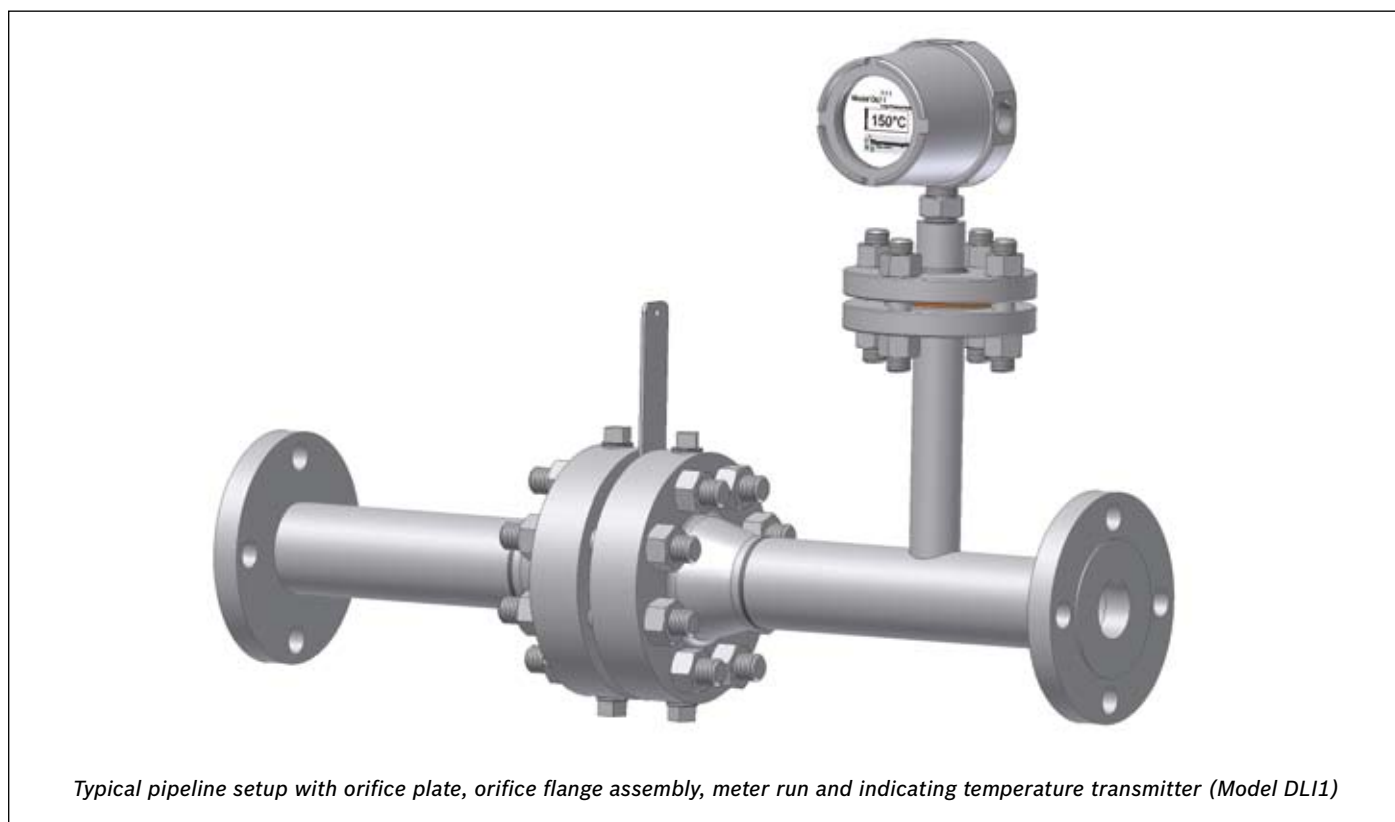

## Differential Pressure Gauges (light to medium duty)

### General Description

Our quality differential pressure gauges are designed to measure the difference in pressure between two points in a system and show it on a single dial gauge. A magnetic movement senses the differential pressure. The gauge has separate pressure and indicating chambers.

These diaphragm instruments can indicate small values of differential pressure even when used at high line pressures. They provide instantaneous and continuous information regarding system conditions helping in eliminating premature servicing of equipment, avoid unscheduled down time of costly processes and can detect abnormal system conditions.

Gauges can be supplied with reed switches to initiate alarms, activate other equipment or to shut the system down. Two switches are used when high and low limits are desired. Gauge-switch models provide the user with both gauge readout and switch operation.

### Applications

Monitor filter conditions, set filter by-pass, or initiate filter cleaning cycle. Determine obstructions in process lines. Check condition of pumps, heat exchangers and other processing equipment. Adjust flow rates in piping systems. Monitor liquid levels in storage tanks.

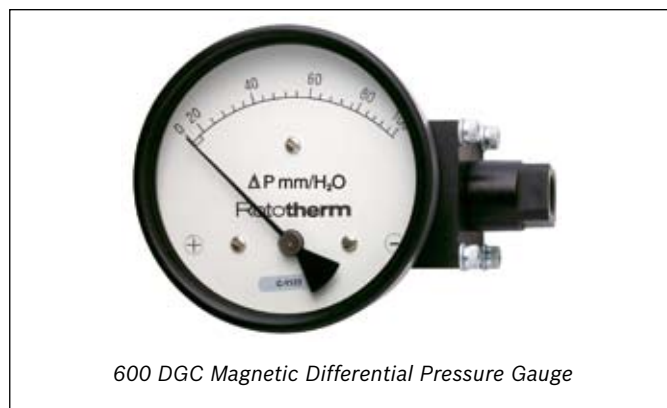





600 DGC Magnetic Differential Pressure Gauge

### Operating Principle

High and low pressures are separated by a sensor assembly consisting of a magnet, piston or diaphragm and a range spring. The difference in pressure causes the sensor assembly to move in proportion to the change against a range spring. A rotary magnet, located in a separate body cavity and isolated from the acting pressures, is rotated by magnetic coupling as per the linear movement of the sensor assembly. A pointer attached to the rotary magnet indicates differential pressure on the dial.

Reed switches are located adjacent to the pressure chamber and are activated by the magnetic field of the sensor assembly.

### Light to Medium Duty Differential Pressure Gauges - Range Overview

Model	Case Material	Mounting	Nominal Dial Sizes (mm)	Body Material / Wetted Parts	Connections*	Standard Ranges**	Maximum Static Pressure	Switch Option
 <b>200DPG</b>	Stainless Steel	Direct Surface Panel 2" pipe	50, 63, 80, 100, 115, 150	Aluminium 316 St Steel Brass	1/4" BSP or NPT female*	0 - 0.25 to 0 - 10 bar	200 bar	SPST or SPDT - one or two
 <b>200DGR</b>	Stainless Steel	Direct Surface Panel 2" pipe	50, 63, 80, 100, 115, 150	Aluminium 316 St Steel Brass	1/4" BSP or NPT female*	0 - 0.25 to 0 - 7 bar	200 bar	SPST or SPDT - one or two
 <b>300DGC</b>	Stainless Steel	Direct Surface Panel 2" pipe	50, 63, 80, 100, 115, 150	Aluminium 316 St Steel Brass	1/4" BSP or NPT female*	0 - 0.075 to 0 - 4 bar	100 bar	SPST or SPDT - one or two
 <b>400DGC</b>	Stainless Steel	Direct Surface Panel 2" pipe	50, 80, 100, 115, 150	Aluminium 316 St Steel	1/4" BSP or NPT female*	0 - 25 to 0 - 600 mmH2O	35 bar	SPST or SPDT - one or two
 <b>600DGC</b>	Stainless Steel	Direct Surface Panel 2" pipe	112	Engineering Polymer	1/8" NPT female*	0 - 15 to 1000 mmH2O	2.4 bar	SPST or SPDT - one or two

\*other connection sizes are available via suitable adaptors

\*\*standard accuracy =  $\pm 2\%$  FSD (Ascending)

## Differential Pressure Gauges (medium to heavy duty)

### General Description

A range of economically priced 100mm and 150mm nominal size differential pressure gauges ideally suited to most medium to heavy duty industrial applications where accuracy and durability is required.

A choice of mounting options enables simple installation - either direct mounting to the process, in a panel, surface mounting on a wall or with a vertical or horizontal pipe mounting.

DP Range - Standard Differential Pressure Range (maximum static pressure)	
0 to 25 mbar (25 bar)	0 to 1.6 bar (100 bar*)
0 to 40 mbar (25 bar)	0 to 2.5 bar (100 bar*)
0 to 60 mbar (25 bar)	0 to 4 bar (100 bar*)
0 to 100 mbar (25 bar)	0 to 6 bar (100 bar*)
0 to 160 mbar (100 bar*)	0 to 10 bar (100 bar*)
0 to 250 mbar (100 bar*)	0 to 16 bar (100 bar*)
0 to 400 mbar (100 bar*)	0 to 25 bar (100 bar*)
0 to 600 mbar (100 bar*)	

\* 200 & 400 bar maximum static pressure options





DP362 Differential Pressure Gauge

DP360, DP370 and DP362 instruments are available with electrical contact head options and can be fitted with diaphragm seal units.

The DP range of differential pressure gauges is also available with a wide range of options including Monel 400 and Hastelloy C276 wetted parts, oxygen cleaning and liquid filled cases. 3 valve and 5 valve integral manifolds are also available.

### Medium to Heavy Duty Differential Pressure Gauges - Range Overview

Model	Case Material	Mounting	Nominal Dial Sizes (mm)	Wetted Parts	Connections*	Standard Pressure Ranges**	Maximum Static Pressure
 <b>DP360</b>	AISI 304 Stainless Steel (316 option)	Direct Surface Panel 2" pipe	100 or 150	AISI 316 stainless steel (NACE option)	1/4" NPT female 1/2" BSP male 1/2" NPT male	0 to 160 mbar to 0 to 25 bar	100 bar (200 bar option)
 <b>DP370</b>	AISI 304 Stainless Steel (316 option)	Direct Surface Panel 2" pipe	100 or 150	AISI 316 stainless steel (NACE option)	1/4" NPT female 1/2" BSP male 1/2" NPT male	0 to 25 mbar to 0 to 100 mbar	25 bar
 <b>DP362</b>	AISI 304 Stainless Steel (316 option)	Direct Surface Panel 2" pipe	100 or 150	AISI 316 stainless steel (NACE option)	1/4" NPT female 1/2" BSP male 1/2" NPT male	0 to 160 mbar to 0 to 25 bar	200 bar (400 bar option)

\*other connection sizes are available

\*\*standard accuracy =  $\pm 1.6\%$  FSD (option for  $\pm 1.0\%$  FSD)

## Clearscan Flow Recorders

The Clearscan range of recorders is suitable for most industrial applications and can be fitted with up to 3 pens for recording temperature, pressure and flow.

- **1, 2 or 3 pen temperature, pressure & flow recording**
- **Uses proven and reliable Rototherm temperature, pressure and differential pressure systems**
- **Simple installation and maintenance requirement**
- **Wall, panel, portable or pipe mounting available**
- **Fully mechanical versions available**
- **Electrical, battery or mechanical chart drive options**
- **Large 12 inch diameter chart**
- **Large choice of temperature, pressure and differential pressure ranges**

### Case

The Clearscan recorder case is made from high quality zinc coated steel, finished in epoxy powder paint that has a high resistance to weathering, scratches and industrial fumes. The window is high quality acrylic. The case has a lockable front-hinged door, permitting easy access to the chart and pens, and may be either wall, panel or pipe mounted.

### Pens

The Clearscan recorders utilise sealed ink capsules with built-in fibre tipped pens which are simple to replace and without any mess. Single pen recorders and the first pen of two and three pen recorders trace in red ink; the second pen of two pen and three pen recorders traces in blue and the third pen of three pen recorders in green. Each recorder is supplied with a spare packet of pens.

### Charts

Clearscan Chart Recorders use a 12 inch circular charts which are interchangeable with Barton, Graphic Controls and Bristol charts. The standard chart durations are one revolution every 24 hours or 7 days - other rotations are available. A pen lift is fitted to ease chart changing. Each recorder is supplied with a packet of 100 charts.

### Chart Drive Motor

The Clearscan Chart Recorder uses chart drive motors that are available as mains powered, mains powered with battery back-up, mechanical (spring-wound) and battery operated with a wide variety of chart speeds (24 hour and 7 day are standard).

### Temperature Systems

The Clearscan chart recorder uses the proven and reliable Rototherm stainless steel thermal system. These consist of a bourdon tube, stainless steel capillary and a stainless steel bulb. All systems are filled with a non toxic filling.

### Pressure Systems

Proven and reliable pressure systems are used to record gauge pressure, vacuum, combined pressure and vacuum, absolute pressure and differential pressure.

### Differential Pressure Unit Specification

#### Pressure Element

AISI 316L 1.4435 stainless steel double welded diaphragm for measuring ranges between 100mbar and 4 bar.  
Duratherm (Co Ni Cr Mo alloy) double welded diaphragm for ranges between 6 and 25 bar.

Wetted parts in 316 stainless steel and Monel 400 to NACE standards are also available.



### Ranges

Standard ranges for pressure values between 100 mbar and 25 bar

### Maximum Static Pressure

Maximum static pressure 200 bar

### Connections

AISI 316L stainless steel: 1/4" NPT female is standard - other connections available include 1/2" BSP male and 1/2" NPT male

### Differential Cell Gaskets

Nitrile rubber (NBR); FPM (Viton®) on request.

Viton® is a registered trademark of DuPont Dow Elastomers



*Rototherm Differential Pressure unit*

### Clearscan Flow Recorder Dimensions

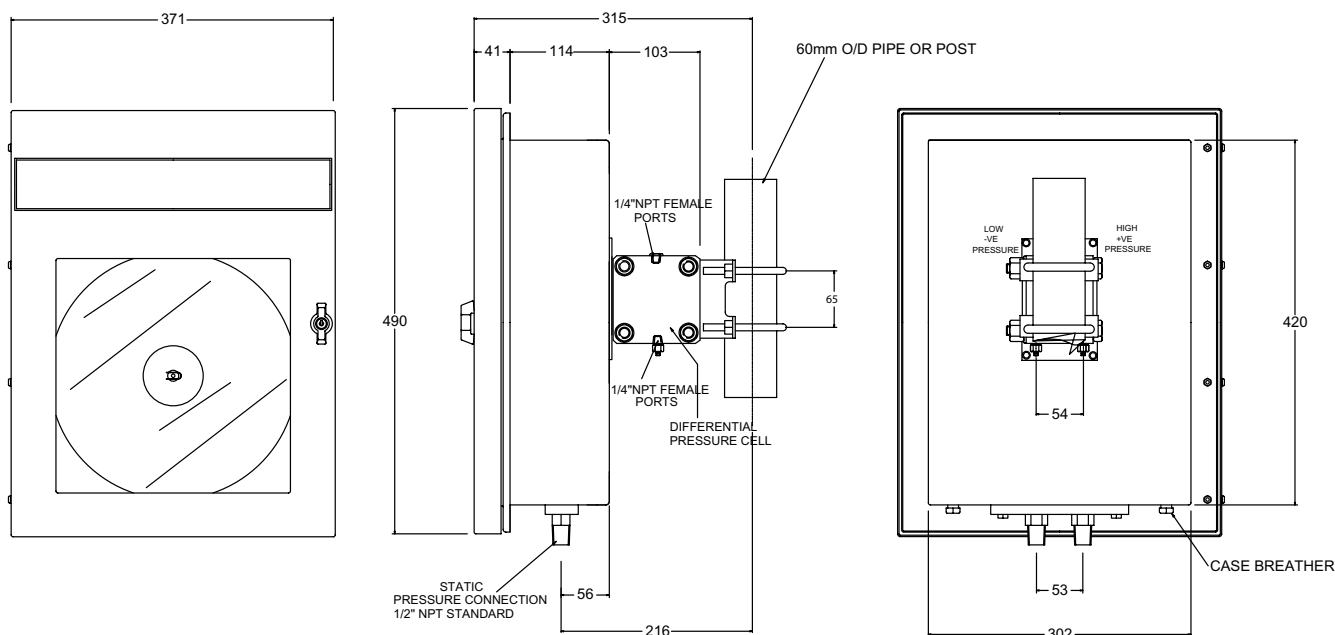

Dimensions for Clearscan Recorder fitted with Differential Pressure Unit  
(all dimensions are in mm)

Standard Temperature Ranges	
-40 to +40 Deg C	0 to 160 Deg C
-30 to +30 Deg C	0 to 200 Deg C
-30 to +50 Deg C	0 to 300 Deg C
-25 to +25 Deg C	0 to 400 Deg C
-25 to 30 Deg C	20 to 120 Deg C
0 to 40 Deg C	50 to 150 Deg C
0 to 50 Deg C	50 to 250 Deg C
0 to 60 Deg C	100 to 400 Deg C
0 to 100 Deg C	100 to 500 Deg C
0 to 120 Deg C	

Standard Differential Pressure Ranges (maximum static pressure)	
0 to 25 mbar (25 bar)	0 to 1.6 bar (100 bar*)
0 to 40 mbar (25 bar)	0 to 2.5 bar (100 bar*)
0 to 60 mbar (25 bar)	0 to 4 bar (100 bar*)
0 to 100 mbar (25 bar)	0 to 6 bar (100 bar*)
0 to 160 mbar (100 bar*)	0 to 10 bar (100 bar*)
0 to 250 mbar (100 bar*)	0 to 16 bar (100 bar*)
0 to 400 mbar (100 bar*)	0 to 25 bar (100 bar*)
0 to 600 mbar (100 bar*)	

Standard Pressure Ranges		
Standard Range	Sensing Element Type	Material
3 to 15 psi 0 to 1 bar 0 to 1.6 bar 0 to 2 bar	Bellows	Beryllium Copper
0 to 2.5 bar 0 to 4 bar 0 to 6 bar 0 to 10 bar 0 to 16 bar 0 to 25 bar 0 to 40 bar 0 to 60 bar 0 to 100 bar	Bourdon Tube	Phosphor Bronze or Stainless Steel
0 to 160 bar 0 to 250 bar 0 to 300 bar 0 to 400 bar 0 to 600 bar 0 to 1,000 bar 0 to 1,200 bar 0 to 1,600 bar	Bourdon Tube	Stainless Steel

\* 200 & 400 bar maximum static pressure options

Calibration in other units of pressure are available

# Orifice Plates, Flow Nozzles & Venturi Tubes

## Installation Instructions

### General

These installation instructions are common to orifice plates, flow nozzles and Venturi tubes, subsequently referred to as the 'primary element'.

The condition of the pipe, the mounting of the primary device, the pressure tapplings, the upstream and downstream straight pipe lengths and the impulse lines all affect measurement accuracy. Installation procedures must be rigidly followed.

These instructions assume the following:-

- The pipeline has a circular cross section
- The pipe is running full at the measuring location
- The primary device is installed in a location where the flow may be considered as having a fully developed profile, and free from swirl.

### Pressure Connections

The location of the pressure tapplings for the various primary elements varies as follows:-

#### Square Edged Orifice Plate

- Flange Tappings - located 25.4 mm upstream and 25.4 mm downstream from the corresponding face of the device.
- Corner Tappings - located right at the upstream and downstream faces of the device.
- D and D/2 Tappings - the upstream tapping located 1 pipe diameter upstream of the device, the downstream tapping located  $\frac{1}{2}$  a pipe diameter downstream of the device.

#### ISA 1932 Flow Nozzle

Corner Tappings - as described above.

#### ASME Long Radius Flow Nozzle

D and D/2 Tappings - as described above.

#### Classical Venturi Tube

Pipe and Throat Tappings - the upstream tapping is located  $\frac{1}{2}$  a pipe diameter upstream of the start of the convergent section and the downstream tapping is located  $\frac{1}{2}$  a throat diameter from the start of the throat.

#### Venturi Nozzle

Corner and Throat Tappings - the upstream tapping is located right at the upstream face and the downstream tapping is located in the throat.

#### Conical Entrance Orifice Plate

Corner Tappings - as described above.

#### Quarter Circle Orifice Plate

- Corner Tappings - up to as described above, for lines up to 40 mm.
- Corner or Flange Tappings - for lines above 40 mm

#### Eccentric Orifice Plate

Corner Tappings - as described above.

### Position of Tappings

#### Gas Measurement

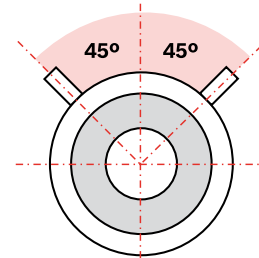

For horizontal clean gas flows, the tapplings should be in the upper half of the pipe, with no more than a  $\pm 45^\circ$  orientation from the vertical.

#### Liquid Measurement

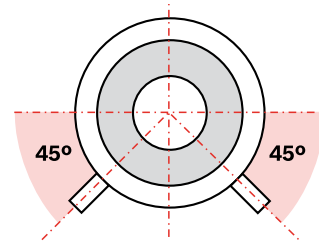

For liquid flows in a horizontal pipe the tapplings should be in the lower half of the pipe, with no more than a  $\pm 45^\circ$  orientation from the horizontal.

#### Steam Measurement

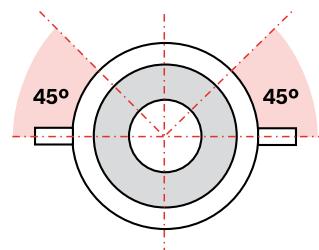

For vapours, and dirty or condensable gases in a horizontal line, the tapplings should be located at the side of the pipe, with no more than a  $\pm 45^\circ$  orientation from the horizontal.

For vertical pipe installations, the pressure taps can be at any radial position around the pipe circumference.

### Piping

The primary device must be fitted between two sections of straight cylindrical pipe, of constant cross sectional area. Pipe straightness and circularity may be determined visually. The required upstream and downstream straight pipe lengths are shown in figures 1 and 2, in terms of pipe diameters.

Seamless pipe is preferred, particularly on small pipe sizes, but seamed pipe may be used, provided the weld bead is parallel to the pipe axis. The seam should not be situated in any sector of  $\pm 30^\circ$  centred on any pressure tapping.

The internal surface of the pipe must be clean and free from encrustations, pittings and deposits. Upper limits of relative roughness may be found in BS EN ISO 5167:1.

Diameter ratio β	Upstream (inlet) Side of the orifice plate																								Downstream (outlet) side of the orifice plate	
	Single 90° bend Two 90° bends in any plane (S>30D) <sup>a</sup>		Two 90° bends in the same plane: S-configuration (30D≥S>10D) <sup>a</sup>		Two 90° bends in the same plane: S-configuration (10D≥S) <sup>a</sup>		Two 90° bends in perpendicular planes (30D≥S>5D) <sup>a</sup>		Two 90° bends in perpendicular planes (5D>S) <sup>a,b</sup>		Single 90° tee with or without an extension Mitre 90° bend		Single 45° bend Two 45° bends in the same plane: S-configuration (S>2D) <sup>c</sup>		Concentric reducer 2D to D over a length of 1.5D to 3D		Concentric expander 0.5D to D over a length of D to 2D		Full bore ball valve or gate valve fully open		Abrupt symmetrical reduction		Thermometer pocket or well of diameter <0.03D <sup>d</sup>			Fittings (columns 2 to 11) and densitometer pocket
1	2		3		4		5		6		7		8		9		10		11		12		13		14	
-	A <sup>e</sup>	B <sup>f</sup>	A <sup>e</sup>	B <sup>f</sup>	A <sup>e</sup>	B <sup>f</sup>	A <sup>e</sup>	B <sup>f</sup>	A <sup>e</sup>	B <sup>f</sup>	A <sup>e</sup>	B <sup>f</sup>	A <sup>e</sup>	B <sup>f</sup>	A <sup>e</sup>	B <sup>f</sup>	A <sup>e</sup>	B <sup>f</sup>	A <sup>e</sup>	B <sup>f</sup>	A <sup>e</sup>	B <sup>f</sup>	A <sup>e</sup>	B <sup>f</sup>	A <sup>e</sup>	B <sup>f</sup>
<0.20	6	3	10	g	10	g	19	18	34	17	3	g	7	g	5	g	6	g	12	6	30	15	5	3	4	2
0.40	16	3	10	g	10	g	44	18	50	25	9	3	30	9	5	g	12	8	12	6	30	15	5	3	6	3
0.50	22	9	18	10	22	10	44	18	75	34	19	9	30	18	8	5	20	9	12	6	30	15	5	3	6	3
0.60	42	13	30	18	42	18	44	18	65 <sup>h</sup>	25	29	18	30	18	9	5	26	11	14	7	30	15	5	3	7	3.5
0.67	44	20	44	18	44	20	44	20	60	18	36	18	44	18	12	6	28	14	18	9	30	15	5	3	7	3.5
0.75	44	20	44	18	44	22	44	20	75	18	44	18	44	18	13	8	36	18	24	12	30	15	5	3	8	4

NOTE 1 The minimum straight lengths required are the lengths between various fittings located upstream or downstream of the orifice plate and the orifice plate itself. Straight lengths shall be measured from the downstream end of the curved portion of the nearest (or only) bend or of the tee or the downstream end of the curved or conical portion of the reducer or expander

NOTE 2 Most of the bends on which the lengths in this table are based had a radius of curvature equal to 1.5D

a S is the separation between the two bends measured from the downstream end of the curved portion of the upstream bend to the upstream end of the curved portion of the downstream bend.  
 b This is not a good upstream installation; a flow conditioner should be used where possible.  
 c The installation of thermometer pockets or wells will not alter the required minimum upstream straight lengths for the other fittings.  
 d A thermometer pocket or well of diameter between 0.03D and 0.13D may be installed provided that the values in Columns A and B are increased to 20 and 10 respectively. Such an installation is not recommended.  
 e Column A for each fitting gives lengths corresponding to "zero additional uncertainty" values  
 f Column B for each fitting gives lengths corresponding to "0.5% additional uncertainty" values  
 g The straight length in Column A gives zero additional uncertainty; data is not available for shorter straight lengths which could be used to give the required straight lengths in Column B  
 h 95D is required for Re<sub>c</sub> > 2 x 10<sup>6</sup> if S < 2D

Values expressed as multiples of internal diameter, D

Fig. 1 - Required Straight lengths between Orifice Plates and Fittings without flow conditioners

Diameter Ratio β	Upstream (inlet) Side of the primary device										Downstream (outlet) side of the primary device
	Single 90° bend or tee (flow from one branch only)	Two or more 90° bends in the same plane	Two or more 90° bends in different planes	Reducer 2D to D over a length 1.5D to 3D	Expander 0.5D to D over a length of D to 2D	Globe valve fully opened	Full bore ball or gate valve fully open	Abrupt symmetrical reduction having a diameter ratio >=0.5	Thermometer pocket of diameter <=0.03D	Thermometer pocket of diameter between 0.03D and 0.13D	
1	2	3	4	5	6	7	8	9	10	11	12
0.20	10	14	34	5	16	18	12	30	5	20	4
0.25	10	14	34	5	16	18	12				4
0.30	10	16	34	5	16	18	12				5
0.35	12	16	36	5	16	18	12				5
0.40	14	18	36	5	16	20	12				6
0.45	14	18	38	5	17	20	12				6
0.50	14	20	40	6	18	22	12				6
0.55	16	22	44	8	20	24	14				6
0.60	18	26	48	9	22	26	14				7
0.65	22	32	54	11	25	28	16				7
0.70	28	36	62	14	30	32	20				7
0.75	36	42	70	22	38	36	24				8
0.80	46	50	80	30	54	44	30				8

Notes  
 1. The minimum straight lengths required are the lengths between the various fittings located upstream or downstream of the primary device and the primary device itself.  
 2. All straight lengths are measured from the upstream face of the primary device.

Fig. 2 - Required Straight length for Flow Nozzles and Venturi Nozzles

**Direction of Flow**

It is critical that the primary element is installed such that the direction of flow is correct (except in the case of bi-directional orifice plates.)

Orifice plates are usually marked to indicate which face is to be upstream. Bevelled plates should be installed with the flat surface upstream.

Flow nozzles and Venturi nozzles have their contoured surface facing upstream. Flanged or weld-in nozzles are usually marked with a flow arrow.

Classical Venturis should be installed with the throat tapping downstream of the pipe tapping.

**Note that in a vertical line, flow should be upwards.**

**Gaskets**

Gaskets or sealing rings should be such that they do not protrude at any point inside the pipe, or across the pressure tappings, particularly when corner tappings are used.

# Installation Instructions

## Installation of DP Transmitter

It is preferable for the impulse lines connecting the primary element to the differential pressure transmitter to be as short as possible. This improves speed of response and reduces the possibility of resonance.

The impulse lines should be close together, and lagged if necessary to reduce density variations due to temperature differences.

Suggested minimum internal diameters for the impulse lines are given in figure 3 below.

Impulse Line Length (m)	Fluid Being Metered			
	Water, Steam, Dry Gas	Wet Gas	Low to Medium Viscosity Fluids	Dry Liquids or Gases
0 - 15	6 mm	9 mm	12.5 mm	25 mm
15 - 40	6 mm	9 mm	18.8 mm	25 mm
40 - 80	12.5 mm	12.5 mm	25 mm	38 mm

Fig. 3 - Suggested Minimum Impulse Line Sizes

## Examples of Installations

Figures 4 and 5 show typical installations for horizontal and vertical pipes.

The transmitters are shown below the level of the pressure connections at the pipe (the usual arrangement except for gas flow without a seal fluid), and with filling tees in the impulse lines (for a seal liquid).

If the process fluid being measured must not come in contact with the transmitter, because of corrosion, dirt or sediment, the impulse lines must be filled with a suitable seal liquid. In steam flows, for instance, the lines are filled with water to protect the transmitter from the hot steam.

Recommended locations for differential pressure transmitters are as follows:-

1. For liquid or steam flow, the transmitter should be mounted lower than the pressure connections at the pipe.
2. For gas flow without a seal liquid, the transmitter should be mounted above the pressure connections at the pipe.
3. For gas flow with a seal liquid, the transmitter should be mounted below the pressure connections.

Fig. 4 - Vertical Process Line Installation

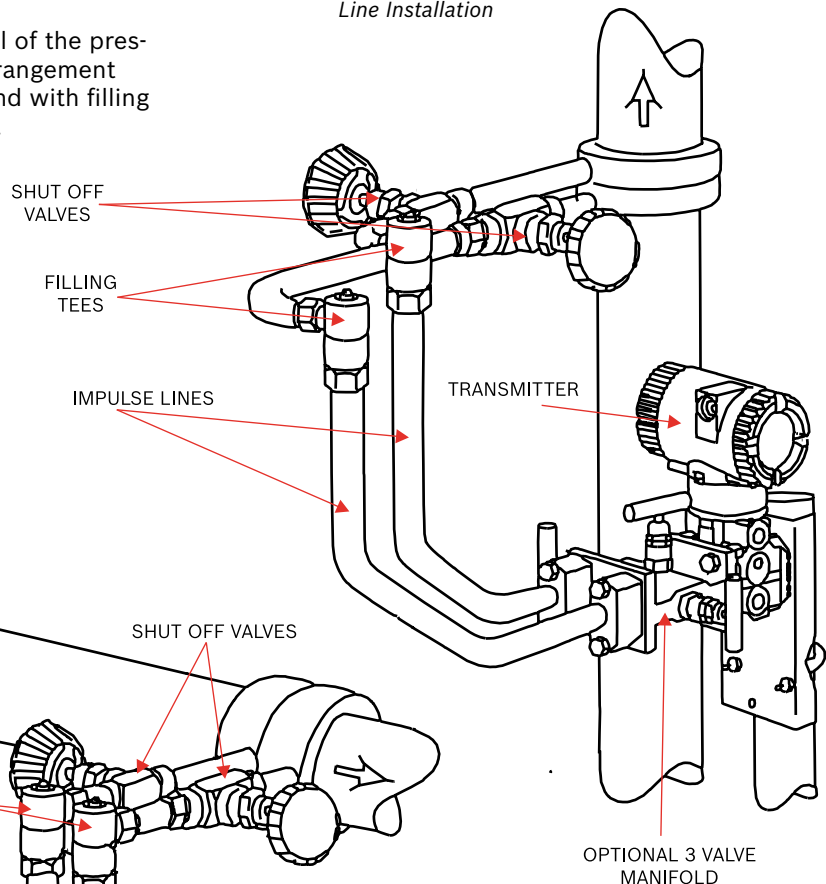
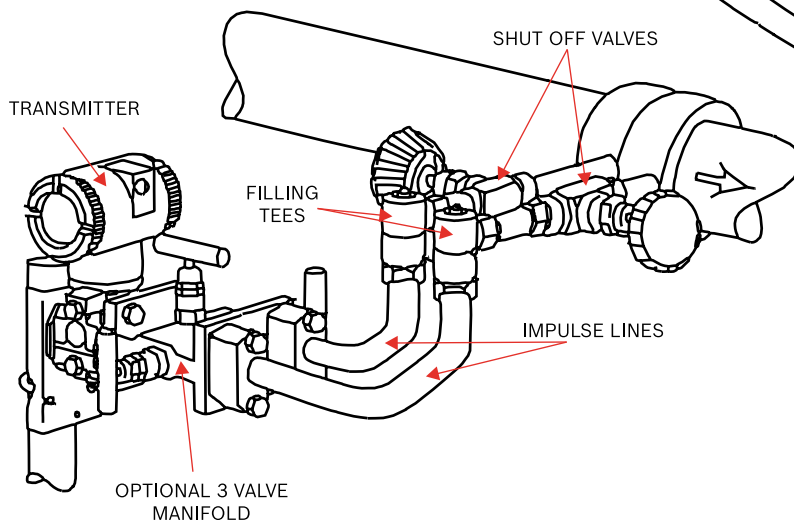

Fig. 4 - Horizontal Process Line Installation



**Maintenance**

Periodic inspection of the primary element is recommended, particularly for square edged orifice plates.

The orifice plate square edge should be checked after six months continuous operation, or more frequently when used on an abrasive fluid. Any dirt or grease should be removed with a suitable solvent. Wear to the square edge can normally be removed by surface grinding the face of the orifice plate, but ultimately a worn orifice plate must be replaced.

**Operation**

Once installation is complete, no operating procedure is required.

**Additional Information**

For additional information on installation and operation of differential pressure primary elements, please refer to BS EN ISO 5167:1, or R.W. Miller’s Flow Measurement Engineering Handbook (ISBN 0-07-042046-7).

For installation details on differential pressure transmitters/gauges, please refer to the manufacturer’s data.

**Orifice Bore Technical Data Requirements**

**Piping Details (at ambient temperature)**

Nominal Line Size	
Schedule	
Pipe Material	

Exact Pipe Inside Diameter <sup>(1)</sup>	
Surface Roughness	
Coefficient of Expansion	

**Flow Element Details**

Element Type <sup>(2)</sup>	
Element Material	
Ambient Temperature	

Coefficient of Expansion	
Bleed Hole Diameter <sup>(3)</sup>	

**Flow Rate and Differential Pressure**

Meter Maximum Flow rate	
Differential Pressure	

Normal Flow Rate	
Reference Density <sup>(4)</sup>	

**Process Conditions**

Fluid Name	
Operating Pressure	
Operating Density	
Isentropic Exponent <sup>(5)</sup>	
Compressibility <sup>(5)</sup>	

Fluid State	
Operating Temperature	
Operating Viscosity	
Molecular Weight <sup>(5)</sup>	

Notes

1. Please advise exact pipe ID if pipe is non-standard, otherwise state nominal size and schedule.
2. For orifice plates, please advise the location of the tapping points.
3. Diameter of vent or drain hole, where appropriate.
4. Please advise fluid density at base conditions when flow rates are specified at normal conditions.
5. Only required when the fluid is in the gas or vapour phase.

## Other products available

### Heavy Duty Bimetallic Thermometers

The Rototherm range of Heavy Duty Bimetallic Thermometers combines robust construction, making these instruments suitable for the most stringent environmental conditions, together with an accurately manufactured bimetallic coil, which ensures a long dependable life.



Rototherm bimetallic thermometers do not contain harmful fill fluids eliminating any possibility of process contamination.

### Light Duty & Surface Temperature Bimetallic Thermometers

Suitable for use on food processing equipment, the completely sealed stainless steel stem makes Rototherm Light Bimetallic Thermometers the ideal choice.



A range of surface mounting bimetallic thermometers suitable for testing, balancing and fault-finding on heating systems. They can be attached to a surface by an adjustable spring or magnet to give an immediate indication of temperature without drilling or cutting.

### Filled System Temperature Indicators

The Rototherm range of filled system thermometers offer tough yet accurate instruments with rigid stems for direct mounting or with flexible capillary for remote reading.

Most models in the range may be specified with electrical contact heads to provide alarm or control functions.

Rototherm non toxic filled system thermometers are designed to give guaranteed reliability over a wide range of ambient temperature conditions and are compensated for ambient temperature changes from -30 to +50°C.



### DA5000 Digital Anemometer

The Rototherm DA5000 Digital Anemometer enables fast, reliable and accurate readings of Air Velocity utilising a high quality rotating vane sensor with either a 25mm (1") or 70mm (2.75") diameter.

DA5000 may be used with either of the Rototherm rotating vane sensors, identification of the connected sensor is displayed automatically when the instrument is switched on.



### Digital Thermometers & Pressure Gauges

A range of Digital Thermometers and Pressure Gauges that employ micro-processor electronics to enable extremely low power consumption to be achieved thus offering extended battery life.

DigiTemp Digital Thermometers are available with either type K thermocouple or high accuracy Pt1000 input.



The combination of high accuracy with stainless steel sensing probes sealed to IP67 enables DigiTemp thermometers to be utilised in many industrial and process applications.

DigiGauge Digital Pressure Gauges offer high accuracy and a 4 digit display - which enables it to be used as a digital standard test gauge. The DigiGauge has been designed to cover a wide range of test and measurement applications with pressure ranges from vacuum to 400 bar.



Both DigiTemp and DigiGauge are offered with the option of a 4 to 20mA retransmission signal and may be specified with maximum and minimum value display. The

addition to the range of intrinsically safe versions allows DigiTemp and DigiGauge to be used in hazardous areas.

### Recorders & Recorder Controllers

An extensive range of circular chart recorders/controllers that include microprocessor based Sentinel multi input recorder/controllers, electrical input recorder/controllers and a wide range of mechanical recorders for temperature, pressure, humidity or flow with, if required, options for electrical or pneumatic control.



The Rototherm range of recorders allow up to 3 pen recording with either 225mm (9"), 255mm (10") or 300mm (12") charts and a range of options that include

recording only or either electric or pneumatic control. A range of pneumatic indicating controllers are also available to control temperature, pressure and humidity.



Rototherm recorders and controllers are both accurate and reliable.

## Temperature Sensors & Thermowells

Our range of Resistance Thermometers and Thermocouples has been designed for all industrial applications

### Temperature Sensors & Thermowells

Our comprehensive range of Thermocouple and Resistance Thermometer Assemblies has been designed to encompass all industrial applications. Assemblies can be ATEX certified for Flame-Proof (EExd), Increased Safety (EExe), Intrinsically Safe (EExia) and EEx nA Non-Incendive Hazardous Areas.



### Temperature Transmitters

An extensive range of high accuracy Programmable & Smart Hart Transmitters are available for both 'Head' and 'Remote' field mounting. These can also be supplied with an integral loop powered indicator. ATEX Certified EExia (Intrinsically Safe) and EEx nA (Non Incendive) any Hazardous area application can be easily covered.

### Thermowells

We offer a complete custom design service for Thermowells which can be manufactured to international standards. Wake Frequency and Stress calculations can be carried out at an early stage to ensure you have the correct design for the process. Our modern factory is equipped with the latest CNC machinery, Deep Hole Drilling machines and semi-automatic welding equipment approved to BS & ASME IX. Thermowells are available manufactured from bar or forgings in all grades of Stainless Steel and exotic materials. We also offer comprehensive N.D.T. testing including Radiography, Ultrasonic, Dye Penetrant and Hydrostatic Pressure Testing. P.M.I. and Full Chemical Analysis.

### Connection Heads & Accessories

A comprehensive range of connection heads in a wide range of materials can be supplied to accommodate both Transmitters & Terminal blocks. Available as ATEX Certified for Flame-Proof (EExd), Increased Safety (EExe), Intrinsically Safe (EExia) and EEx nA Non-Incendive Hazardous Areas.

## Other Catalogues Available

To complement this flow catalogue, a series of other publications are available detailing these and other products in the Rototherm and Thermocouple range.

### Product Guide

Thermometer, chart recorders, controllers, thermowells, orifice plates and temperature sensors

### Pressure Gauge Catalogue

Process gauges, test gauges, diaphragm seal units, differential pressure gauges, digital pressure gauges, pressure transmitters and pressure gauge accessories.

### Temperature Catalogue

Temperature assemblies, temperature transmitters, connection heads, thermowells and accessories.

## Pressure Gauges

British Rototherm has worked hard to establish itself as a world class manufacturer of pressure gauges.

With the acquisition of the pressure gauge manufacturer Sydney Smith Dennis (SSD) in 1998, Rototherm's range of pressure gauges dramatically increased to include gauges to suit most industrial applications.

The Rototherm range of pressure gauges now includes a comprehensive selection of process, utility, test, absolute and differential pressure gauges. To complement these gauges a range of accessories are available that include diaphragm seal units and electrical contact heads.

### Process Gauges

A wide range of process gauges are offered including full safety pattern, stainless steel cased Elite safety pattern gauges and high corrosion resistant DMC plastic cased pressure gauges. Low range capsule gauges are also offered. The range also includes Elite Pressur Gauges with integral 5 amp switches



### Differential Pressure Gauges

A range of high quality, cost effective and reliable differential pressure gauges designed to measure the difference in pressure between two points in a system and show it on a single dial gauge. With their simple and compact design this range offers outstanding value for money.



### Pressure Transmitters

The Rototherm range of Pressure Transmitters provide a 4 to 20 mA output signal by utilising a diaphragm strain gauge mounted with an amplifier in a stainless steel housing. This reliable range of instruments are rugged and easy to install.



**Request your catalogue by contacting the Rototherm / Thermocouple Sales Department**

With over seventy years of experience, British Rototherm continues to be a world leader in the manufacture of industrial instrumentation for measuring, monitoring and controlling Temperature, Pressure, Humidity, Flow and Level.

British Rototherm and Thermocouple Instruments products are manufactured in its modern factory located in the South Wales region of the United Kingdom. Sited on 6 acres of land at Kenfig Industrial Estate, the company operates from a modern 6,030 square metre (65,000 square feet) factory.

Suitable for many industrial applications, Rototherm / Thermocouple products are precision built to the highest quality.

Approved by major companies and contractors in the United Kingdom and throughout the world for the supply of instrumentation and associated products, Rototherm / Thermocouple products are specified and installed wherever reliability and long lasting, accurate performance is demanded.

The Rototherm / Thermocouple range of instrumentation include:

- *Mechanical Recorders & Recorder Controllers*
- *Pneumatic Indicators & Recorder Controllers*
- *Thermometers*
- *Digital Thermometers*
- *Digital Process Indicators*
- *Pressure Gauges*
- *Digital Pressure Gauges*
- *Thermowells*
- *Temperature Sensors & Assemblies*
- *Orifice & Restriction Orifice Plates*
- *Digital Anemometers*
- *Recorder Charts, Pens & Spares*

### British Rototherm Company Limited

Kenfig Industrial Estate, Margam, Port Talbot SA13 2PW, United Kingdom

Telephone: +44 (0) 1656 740 551 Facsimile: +44 (0) 1656 745 915

E-mail: [sales@rototherm.co.uk](mailto:sales@rototherm.co.uk) [sales@thermocouple.co.uk](mailto:sales@thermocouple.co.uk)

Web site: [www.rototherm.co.uk](http://www.rototherm.co.uk) [www.thermocouple.co.uk](http://www.thermocouple.co.uk)



ISO9001:2000  
FM11958

 **Rototherm**<sup>™</sup>  
instrumentation and control

 **Thermocouple**<sup>™</sup>  
Instruments