

RTJ Type Orifice Plates

Design Generally to BS EN ISO 5167

Range of Orifice Types

Concentric Square Edge

Restriction

Range of Designs

One Piece Construction

Screwed On Plate

Proven technology

Suitable for 1" lines and above

Orifice sizing on request

General Description

The RTJ type orifice plate incorporates an integral gasket, either oval or octagonal ring, for mounting between ring type joint flanges. It is based on proven technology, has no moving parts and is suitable for high temperature and pressure applications. Orifice plates are recommended for clean liquids, gases and low velocity steam flows.

Dimensions

Plate thicknesses depend on line size and differential pressure, and should be sufficient to prevent the plate from bending under operating conditions. Recommended plate thicknesses for flow measurement plates are shown in Figure 1.

Thermocouple Instruments Ltd standard plate and ring dimensions are shown in Figure 2. Orifice plates can be made in accordance with customer drawings as required.

Pipe Diameter	Standard Plate Thickness (mm) for Differential Pressure P		
	P = 250 mbar	P = 251 – 500 mbar	P = 501 – 2500 mbar
D 150 mm	3	3	3
200 D 250	3	3	6
300 D 500	6	6	10
600 D 00			
0.5	10	10	12
0.5	6	10	12

Figure 1 - Recommended Orifice Plate Thicknesses

Orifice Flange Assemblies

RTJ type orifice plates can be supplied complete with ANSI B16.36 orifice flanges. Please refer to Product Data Sheet FM-CR/FLGA for further details. Meter runs are also available.



RTJ Type Orifice Plate

Materials

RTJ type orifice plates may be machined in one piece, or alternatively from two pieces, with an orifice plate screwed onto a carrier ring/gasket. Standard material grades for orifice plates include 316 Stainless Steel, 304 Stainless Steel, 310 Stainless Steel, Hastelloy® C276, Hastelloy® B3, Duplex Stainless Steel, Super Duplex Stainless Steel, Monel® 400, Carbon Steel, Titanium, Incoloy® 800, Incoloy® 825, Inconel® 600 and Inconel® 625.

Common carrier ring/gasket materials include Stainless Steel and soft iron. To ensure correct sealing when installed between flanges, the hardness of the carrier ring/gasket material is limited to a maximum value, typically 120 for soft iron rings and 160 for Stainless Steel Rings.

Please contact the sales office for other grades.

Orifice Bore Sizing

Orifice calculations for flow measurement plates are performed to the latest revision of BS EN ISO 5167, when requested.

Orifice calculations for restriction plates are performed generally in accordance with the formulae in RW Miller's Flow Measurement Handbook, when requested.

The Thermocouple Instruments Ltd sizing programs, DPCalc and ROCalc are also available for purchase. For more details, please refer to Product Data Sheets FM-SW/DPCA and FM-SW/ROCA respectively.

Standard Plate and Ring Dimensions

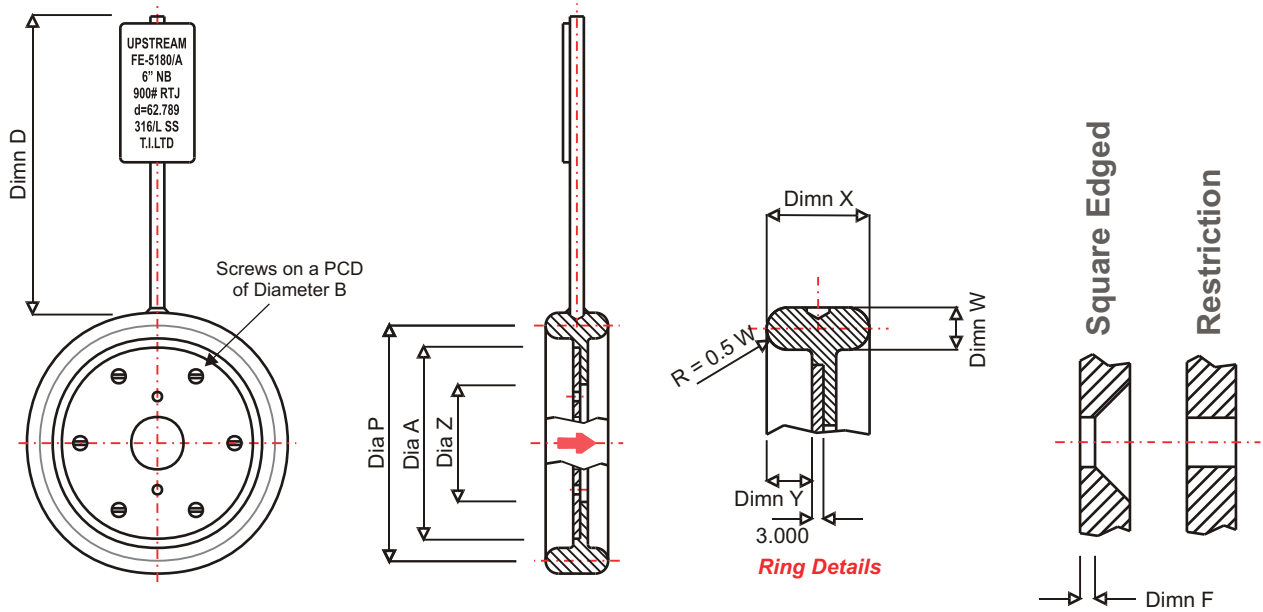

RATING AND LINE SIZE (INCHES)				RING No	DIA P	DIMN W	DIMN X	DIMN Y	DIA Z	DIMN F	DIA A	DIA B	DIMN D
300 # 600 #	900 #	1500 #	2500 #										
1	1	1		R 16	50.8	7.9	23.8	10.3	25.4	0.5	41.3	33.3	125
			1	R 18	60.2	7.9	23.8	10.3	25.4	0.5	41.3	33.3	150
1.5	1.5	1.5		R 20	68.3	7.9	23.8	10.3	38.1	0.5	54	46	125
			1.5	R 23	82.5	11.1	27	10.3	38.1	0.5	54	46	150
2		2		R 23	82.5	11.1	27	11.9	50.8	0.75	69.8	60.3	125
	2	2		R 24	95.3	11.1	27	11.9	50.8	0.75	82.55	66.6	150
			2	R 26	101.6	11.1	27	11.9	50.8	0.75	82.55	66.6	150
2.5				R 26	101.6	11.1	27	11.9	63.5	0.75	85.5	69.5	125
	2.5	2.5		R 27	107.9	11.1	27	11.9	63.5	0.75	91.8	75.8	150
			2.5	R 28	111.1	12.7	27	11.9	63.5	0.75	93.4	77.4	150
3	3			R 31	123.8	11.1	27	11.9	76.2	1	107.9	92	150
			3	R 32	127	12.7	28.6	12.7	76.2	1	107.9	92	150
		3		R 35	136.5	11.1	27	11.9	76.2	1	107.9	92	150
4	4			R 37	149.2	11.1	27	11.9	104	1.5	136.5	120.6	150
			4	R 38	157.2	15.9	31.7	14.3	104	1.5	136.5	120.6	150
		4		R 39	162	11.1	27	11.9	104	1.5	136.5	120.6	150
6	6			R 45	211.1	11.1	27	11.9	158.7	1.5	190.5	174.6	150
		6		R 46	211.1	12.7	34.9	12.7	158.7	1.5	190.5	174.6	150
			6	R 47	228.6	19.1	27	15.9	158.7	1.5	190.5	174.6	175
8	8			R 49	269.9	11.1	27	11.9	209.5	3.5	241.3	225.4	175
		8		R 50	269.9	15.9	31.7	14.3	209.5	3.5	241.3	225.4	175
			8	R 51	279.4	22.2	38.1	17.5	209.5	3.5	241.3	225.4	175
10	10			R 53	323.8	11.1	27	11.9	260.3	3.5	292.1	276.2	175
		10		R 54	323.8	15.9	31.7	14.3	260.3	3.5	292.1	276.2	175
			10	R 55	342.9	28.6	46	21.4	260.3	3.5	292.1	276.2	200
12	12			R 57	381	11.1	27	11.9	311.2	3.5	342.9	327	175
		12		R 58	381	22.2	38.1	17.5	311.2	3.5	342.9	327	175
			12	R 60	406.4	31.7	49.2	23	311.2	3.5	342.9	327	200
14 OD				R 61	419.1	11.1	27	11.9	343	5	374.6	358.8	150
	14 OD			R 62	419.1	15.9	31.7	14.3	343	5	374.6	358.8	175
		14 O D		R 63	419.1	25.4	27	19.8	343	5	374.6	358.8	175
16 OD				R 65	469.9	11.1	27	11.9	393.7	5	425.4	409.6	150
	16 OD			R 66	469.9	15.9	31.7	14.3	393.7	5	425.4	409.6	200
		16 O D		R 67	469.9	28.6	46	21.4	393.7	5	425.4	409.6	200
18 OD				R 69	533.4	11.1	27	11.9	444.5	5	476.2	460.4	175
	18 OD			R 70	533.4	19.1	34.9	15.9	444.5	5	476.2	460.4	200
		18 O D		R 71	533.4	28.6	46	21.4	444.5	5	476.2	460.4	200
20 OD				R 73	584.2	12.7	28.6	12.7	495.3	8	517.5	501.6	175

Figure 2 - Standard Plate and Ring Dimensions